

Based on
NCF 2022 for
Foundational
Stage and NIPUN
BHARAT 2021

PMP Planet[®]
Multimedia Publishers
The Ultimate Resource



Skillment

MATHEMATICS

A Multi-skill Activity Book on Mathematics



1

FS-5
Class - 2



2



3



ANSWER KEY

1

Numbers up to 200



Get Ready

1. Represent the following numbers on abacus.

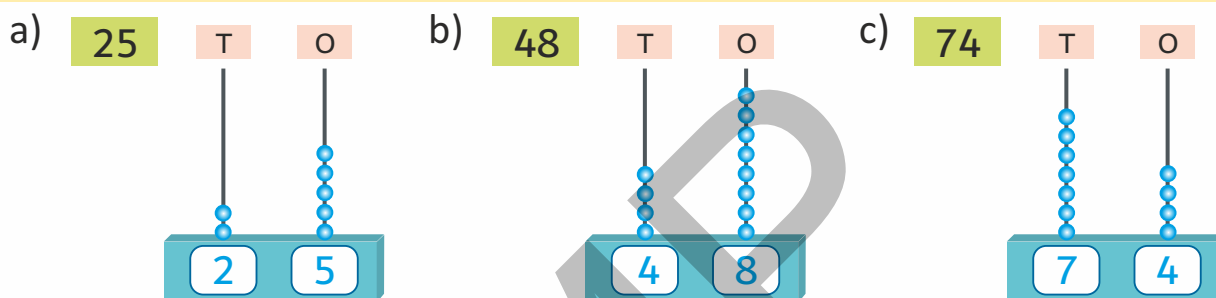

2. Write the following numbers in tens and ones.

a) $36 = 3 \text{ tens and } 6 \text{ ones}$

b) $44 = 4 \text{ tens and } 4 \text{ ones}$

c) $59 = 5 \text{ tens and } 9 \text{ ones}$

d) $80 = 8 \text{ tens and } 0 \text{ ones}$

3. Match the numbers with number names.

a) 27	—	i) Forty-eight
b) 48	—	ii) Seventy-five
c) 64	—	iii) Ninety-six
d) 75	—	iv) Twenty-seven
e) 96	—	v) Sixty-four



4. Put the sign $<$, $>$, or $=$ in the boxes.

a)	$39 < 42$	b)	$54 < 60$	c)	$84 > 59$	d)	$40 < 60$
	$28 = 28$		$74 > 37$		$96 > 92$		$85 > 84$

5. Write the following in ascending order.

a)	45	64	39	55	—	39	45	55	64
b)	82	86	99	94	—	82	86	94	99
c)	59	34	22	60	—	22	34	59	60
d)	35	54	59	37	—	35	37	54	59

6. Write the following in descending order.

a)	38	22	56	93	—	93	56	38	22
b)	82	44	69	76	—	82	76	69	44
c)	72	79	86	85	—	86	85	79	72
d)	52	67	58	69	—	69	67	58	52

7. Complete the numbers from 1 to 100.

1	2	3	4	5	6	7	8	9	10
11	12	13	14	15	16	17	18	19	20
21	22	23	24	25	26	27	28	29	30
31	32	33	34	35	36	37	38	39	40
41	42	43	44	45	46	47	48	49	50
51	52	53	54	55	56	57	58	59	60
61	62	63	64	65	66	67	68	69	70
71	72	73	74	75	76	77	78	79	80
81	82	83	84	85	86	87	88	89	90
91	92	93	94	95	96	97	98	99	100



Quick Response 1.1

1. Say the number aloud as you write them.

a)  +  + 

H	T	O
1	2	4

b)  +  + 

H	T	O
1	4	4

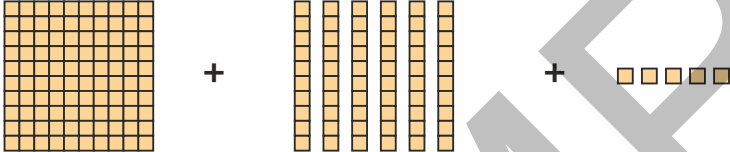
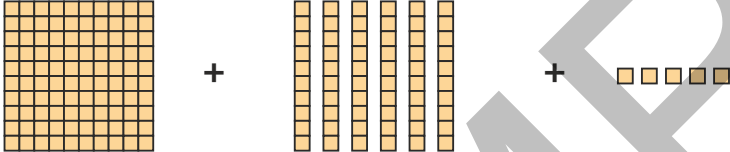
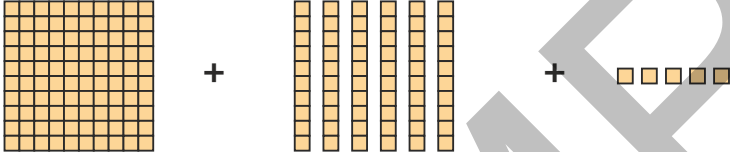
c)  +  + 

H	T	O
1	6	5

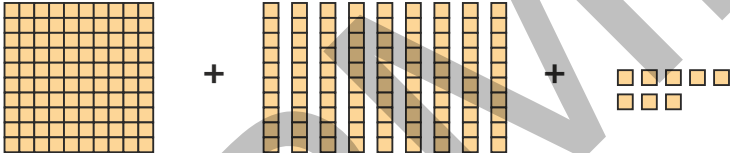
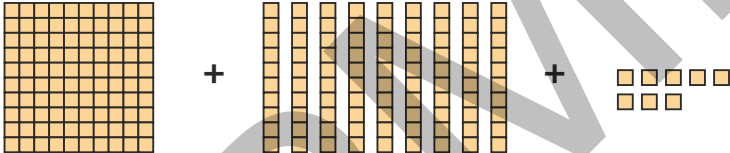
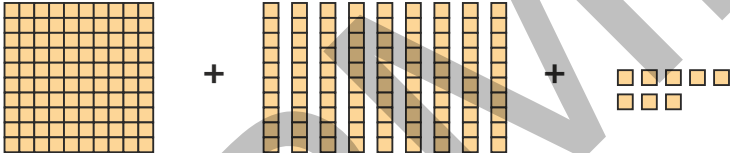
d)  +  + 

H	T	O
1	9	8

2. Write the missing numbers.

101	102	103	104	105	106	107	108	109	110
111	112	113	114	115	116	117	118	119	120
121	122	123	124	125	126	127	128	129	130
131	132	133	134	135	136	137	138	139	140
141	142	143	144	145	146	147	148	149	150
151	152	153	154	155	156	157	158	159	160
161	162	163	164	165	166	167	168	169	170
171	172	173	174	175	176	177	178	179	180
181	182	183	184	185	186	187	188	189	190
191	192	193	194	195	196	197	198	199	200



3. Write the following in numerals.

- a) One hundred twelve
- b) One hundred thirty-six
- c) One hundred forty-four
- d) One hundred eighty-four
- e) One hundred ninety-three

112

136

144

184

193



4. Write the following in words.

- a) 119 = One hundred nineteen
- b) 145 = One hundred forty five
- c) 168 = One hundred sixty eight
- d) 177 = One hundred seventy seven
- e) 187 = One hundred eighty seven



5. Write the number that comes after:

- a) 110 → 111
- b) 125 → 126
- c) 137 → 138
- d) 146 → 147
- e) 156 → 157
- f) 165 → 166
- g) 175 → 176
- h) 186 → 187

6. Write the number that comes before:

- a) 108 → 109
- b) 119 → 120
- c) 138 → 139
- d) 143 → 144
- e) 155 → 156
- f) 162 → 163
- g) 179 → 180
- h) 199 → 200

7. Write the number that comes between:

- a) 124 → 125 → 126
- b) 129 → 130 → 131
- c) 145 → 146 → 147
- d) 159 → 160 → 161
- e) 178 → 179 → 180
- f) 195 → 196 → 197

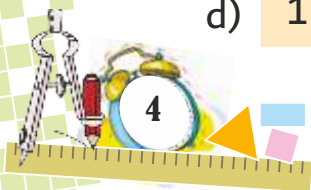



Quick Response 1.2

Write the place value and face value of the following digits.

	Place Value	Face Value		Place Value	Face Value
1. 3 in 123	3	3	5. 1 in 172	100	1
2. 4 in 145	40	4	6. 6 in 167	60	6
3. 5 in 156	50	5	7. 1 in 198	100	1
4. 7 in 117	7	7	8. 9 in 190	90	9



Quick Response 1.3

1. Write the following in expanded form.

a) 105 =	100 + 5	e) 117 =	100 + 10 + 7
b) 128 =	100 + 20 + 8	f) 136 =	100 + 30 + 6
c) 149 =	100 + 40 + 9	g) 160 =	100 + 60
d) 181 =	100 + 80 + 1	h) 199 =	100 + 90 + 9

2. Write the following in short form.

a) 100 + 4 =	104	e) 100 + 50 + 1 =	151
b) 100 + 30 + 7 =	137	f) 100 + 70 + 4 =	174
c) 100 + 50 + 9 =	159	g) 100 + 80 + 9 =	189
d) 100 + 60 =	160	h) 100 + 90 =	190





Quick Response 14

1. Put the sign $>$, $<$ or $=$ in the boxes.

a) $107 < 117$

b) $98 < 100$

c) $154 = 154$

d) $166 < 177$

e) $172 > 160$

f) $125 > 57$

g) $187 < 199$

h) $151 > 105$

i) $134 = 134$

j) $17 < 34$

k) $107 < 119$

l) $138 > 129$

2. Write the following in ascending order.

a) $164, 114, 161, 152 = 114, 152, 161, 164$

b) $172, 107, 171, 179 = 107, 171, 172, 179$

c) $154, 70, 69, 175 = 69, 70, 154, 175$

d) $189, 182, 196, 199 = 182, 189, 196, 199$

3. Write the following in descending order.

a) $104, 114, 162, 153 = 162, 153, 114, 104$

b) $119, 99, 67, 100 = 119, 100, 99, 67$

c) $127, 181, 189, 134 = 189, 181, 134, 127$

d) $154, 125, 153, 121 = 154, 153, 125, 121$

Odd and Even Numbers

Do it yourself





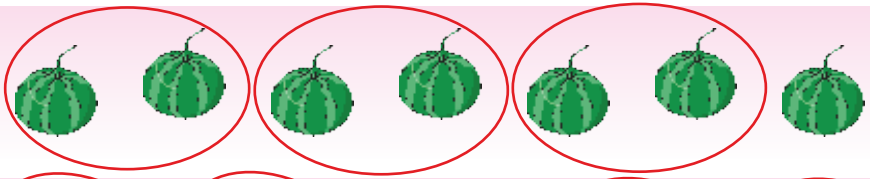

Quick Response 15

1. Make pairs of the following objects by circling two objects each time. Write whether the number is even or odd.

a) 

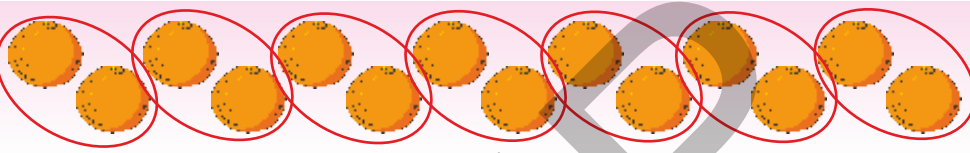
b) 

c) 

d) 

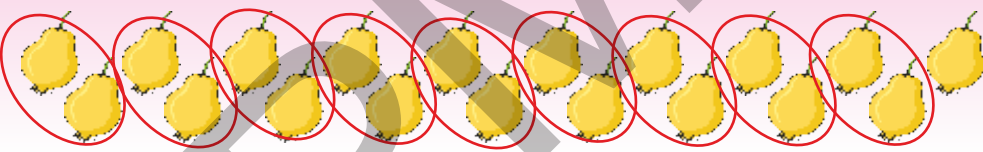
e) 

2. Circle the even numbers.

a) 21 22 23 24 25 26

b) 33 44 55 59 62 78

c) 87 77 71 67 89 94

d) 102 105 107 108 109 110

e) 125 137 138 140 151 159





Quick Response 1.6

Colour the objects as directed in the box.

1. 3rd from left



2. 6th from right

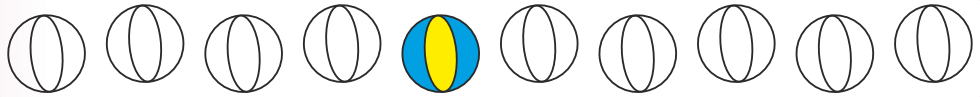

3. 8th from left

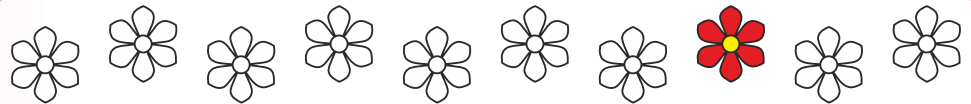

4. 9th from left



5. 7th from right



PMP





Chapter Review

1. Write the following in numbers.

a) One hundred sixty-four

b) One hundred eighty-nine

2. Write the following in words.

a) 156 =

b) 177 =

3. Write the place value and face value of the circled digits.

a) $1\text{(}2\text{)}5$ =

Place Value	Face Value
<input type="text" value="20"/>	<input type="text" value="2"/>

 b) $1\text{(}0\text{)}4$ =

Place Value	Face Value
<input type="text" value="0"/>	<input type="text" value="0"/>

c) $\text{(}1\text{)}76$ =

Place Value	Face Value
<input type="text" value="100"/>	<input type="text" value="1"/>

 d) $19\text{(}8\text{)}$ =

Place Value	Face Value
<input type="text" value="8"/>	<input type="text" value="8"/>

4. Write the following in expanded form.

a) 137 =

b) 160 =

5. Write the following in short form.

a) $100 + 7 =$

b) $100 + 50 + 5 =$

6. Put $<$, $>$ or $=$ in the boxes.

a) 105 117

b) 98 100

c) 128 128

d) 167 129

e) 115 135

f) 196 191

7. Write the following in ascending order.

a) 125, 101, 98, 117 =

b) 195, 187, 198, 185 =



8. Write the following in descending order.

a) 187, 84, 171, 117 = 187, 171, 117, 84

b) 106, 195, 107, 197 = 197, 195, 107, 106

9. Circle the odd numbers.

a) 5, 13, 21, 37, 56, 91

b) 55, 105, 117, 164, 185, 190



10. Circle the objects as directed in the boxes.

a) 4th from left

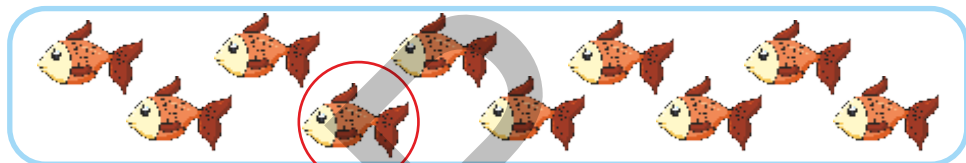

b) 7th from right



c) 8th from left



d) 9th from right



Critical Thinking

1. There are 12 children standing in a queue. If Kavya is standing at third position from the starting place, what is her position from the end?

Ans. 10

2. Which of the following numbers will be the greatest if their ones and tens digits are interchanged?

109, 116, 125, 192, 186



Cleanliness of our neighbourhood is very important because it makes our surroundings beautiful. Moreover, we can prevent many diseases by keeping our neighbourhood clean. In a locality, the people have planned to install a dustbin in front of every tenth house. If there are 120 houses in the neighbourhood, how many dustbins are required? _____12_____

How can you help in keeping your neighbourhood clean? We can request all our neighbours to put the garbage into dustbins.

PMP



2

Addition



Get Ready

1. Add the following on the number line.

a) $3 + 7 = 10$

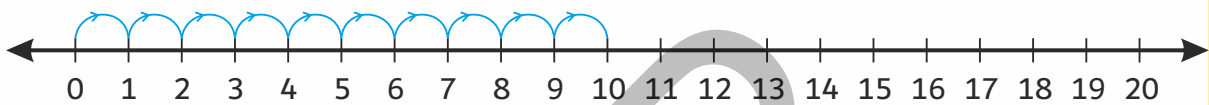

b) $15 + 4 = 19$

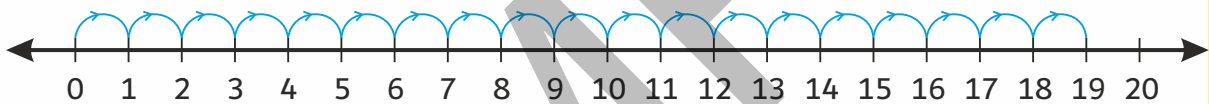

2. Add the following by counting forward.

a) $27 + 4 = 31$

b) $33 + 3 = 36$

c) $80 + 6 = 86$

d) $78 + 9 = 87$



3. Add the following. Regroup if required.

	T	O
	4	2
+	3	7
	7	9

	T	O
	5	8
+	2	0
	7	8

	T	O
	3	5
+	2	7
	6	2

	T	O
	4	6
+	2	4
	7	0



4. An egg seller sold 34 eggs in the morning and 24 eggs in the evening. How many eggs did he sell altogether?

	3	4
+	2	4
	5	8





Quick Response 2.1

Add the following.

$$\begin{array}{r} \text{T} \quad \text{O} \\ 3 \quad 2 \\ + 2 \quad 6 \\ \hline 5 \quad 8 \end{array}$$

$$\begin{array}{r} \text{T} \quad \text{O} \\ 4 \quad 5 \\ + 3 \quad 2 \\ \hline 7 \quad 7 \end{array}$$

$$\begin{array}{r} \text{T} \quad \text{O} \\ 6 \quad 4 \\ + 2 \quad 0 \\ \hline 8 \quad 4 \end{array}$$

$$\begin{array}{r} \text{T} \quad \text{O} \\ 3 \quad 8 \\ + 4 \quad 1 \\ \hline 7 \quad 9 \end{array}$$

$$\begin{array}{r} \text{T} \quad \text{O} \\ 4 \quad 5 \\ + 3 \quad 3 \\ \hline 7 \quad 8 \end{array}$$

$$\begin{array}{r} \text{T} \quad \text{O} \\ 5 \quad 4 \\ + 0 \quad 4 \\ \hline 5 \quad 8 \end{array}$$

$$\begin{array}{r} \text{T} \quad \text{O} \\ 6 \quad 3 \\ + 2 \quad 5 \\ \hline 8 \quad 8 \end{array}$$

$$\begin{array}{r} \text{T} \quad \text{O} \\ 7 \quad 6 \\ + 1 \quad 2 \\ \hline 8 \quad 8 \end{array}$$

$$\begin{array}{r} \text{T} \quad \text{O} \\ 8 \quad 2 \\ + 1 \quad 5 \\ \hline 9 \quad 7 \end{array}$$

$$\begin{array}{r} \text{T} \quad \text{O} \\ 7 \quad 1 \\ + 2 \quad 8 \\ \hline 9 \quad 9 \end{array}$$

$$\begin{array}{r} \text{T} \quad \text{O} \\ 6 \quad 0 \\ + 2 \quad 5 \\ \hline 8 \quad 5 \end{array}$$

$$\begin{array}{r} \text{T} \quad \text{O} \\ 7 \quad 4 \\ + 2 \quad 3 \\ \hline 9 \quad 7 \end{array}$$



Quick Response 2.2

Change the order of the addends and find the sum.

$$1. \quad 54 + 33$$

$$\begin{array}{r} \text{T} \quad \text{O} \\ 5 \quad 4 \\ + 3 \quad 3 \\ \hline 8 \quad 7 \end{array} \quad \begin{array}{r} \text{T} \quad \text{O} \\ 3 \quad 3 \\ + 5 \quad 4 \\ \hline 8 \quad 7 \end{array}$$

$$2. \quad 62 + 26$$

$$\begin{array}{r} \text{T} \quad \text{O} \\ 6 \quad 2 \\ + 2 \quad 6 \\ \hline 8 \quad 8 \end{array} \quad \begin{array}{r} \text{T} \quad \text{O} \\ 2 \quad 6 \\ + 6 \quad 2 \\ \hline 8 \quad 8 \end{array}$$





Quick Response 2.3

Regroup the following. One has been done for you.

- 2 tens 12 ones = 3 tens 2 ones
- 4 tens 15 ones = 5 tens 5 ones
- 3 tens 11 ones = 4 tens 1 one
- 5 tens 16 ones = 6 tens 6 ones
- 8 tens 17 ones = 9 tens 7 ones
- 6 tens 14 ones = 7 tens 4 ones

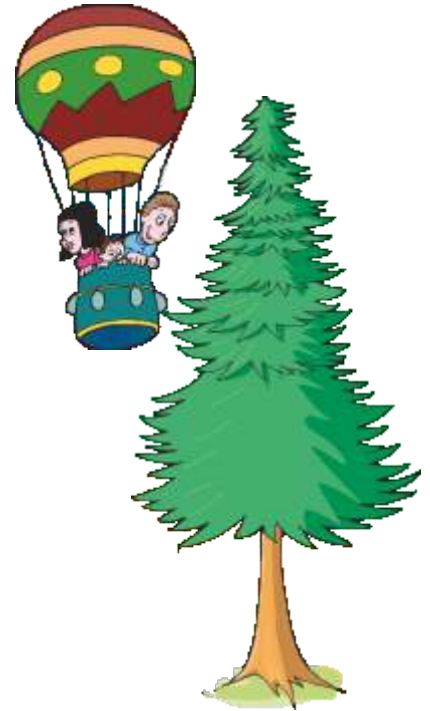

Quick Response 2.4

Add the following.

- | 1. | <table border="1"><tr><th>T</th><th>O</th></tr><tr><td>2</td><td>4</td></tr><tr><td>+</td><td>3</td></tr><tr><td>6</td><td>2</td></tr></table> | T | O | 2 | 4 | + | 3 | 6 | 2 | 2. | <table border="1"><tr><th>T</th><th>O</th></tr><tr><td>3</td><td>7</td></tr><tr><td>+</td><td>3</td></tr><tr><td>7</td><td>2</td></tr></table> | T | O | 3 | 7 | + | 3 | 7 | 2 | 3. | <table border="1"><tr><th>T</th><th>O</th></tr><tr><td>1</td><td>9</td></tr><tr><td>+</td><td>2</td></tr><tr><td>4</td><td>6</td></tr></table> | T | O | 1 | 9 | + | 2 | 4 | 6 | 4. | <table border="1"><tr><th>T</th><th>O</th></tr><tr><td>3</td><td>9</td></tr><tr><td>+</td><td>0</td></tr><tr><td>4</td><td>8</td></tr></table> | T | O | 3 | 9 | + | 0 | 4 | 8 | 5. | <table border="1"><tr><th>T</th><th>O</th></tr><tr><td>4</td><td>2</td></tr><tr><td>+</td><td>2</td></tr><tr><td>7</td><td>0</td></tr></table> | T | O | 4 | 2 | + | 2 | 7 | 0 |
|-----|--|---|---|---|---|---|---|---|---|-----|--|---|---|---|---|---|---|---|---|-----|--|---|---|---|---|---|---|---|---|-----|--|---|---|---|---|---|---|---|---|-----|--|---|---|---|---|---|---|---|---|
| T | O | | | | | | | | | | | | | | | | | | | | | | | | | | | | | | | | | | | | | | | | | | | | | | | | |
| 2 | 4 | | | | | | | | | | | | | | | | | | | | | | | | | | | | | | | | | | | | | | | | | | | | | | | | |
| + | 3 | | | | | | | | | | | | | | | | | | | | | | | | | | | | | | | | | | | | | | | | | | | | | | | | |
| 6 | 2 | | | | | | | | | | | | | | | | | | | | | | | | | | | | | | | | | | | | | | | | | | | | | | | | |
| T | O | | | | | | | | | | | | | | | | | | | | | | | | | | | | | | | | | | | | | | | | | | | | | | | | |
| 3 | 7 | | | | | | | | | | | | | | | | | | | | | | | | | | | | | | | | | | | | | | | | | | | | | | | | |
| + | 3 | | | | | | | | | | | | | | | | | | | | | | | | | | | | | | | | | | | | | | | | | | | | | | | | |
| 7 | 2 | | | | | | | | | | | | | | | | | | | | | | | | | | | | | | | | | | | | | | | | | | | | | | | | |
| T | O | | | | | | | | | | | | | | | | | | | | | | | | | | | | | | | | | | | | | | | | | | | | | | | | |
| 1 | 9 | | | | | | | | | | | | | | | | | | | | | | | | | | | | | | | | | | | | | | | | | | | | | | | | |
| + | 2 | | | | | | | | | | | | | | | | | | | | | | | | | | | | | | | | | | | | | | | | | | | | | | | | |
| 4 | 6 | | | | | | | | | | | | | | | | | | | | | | | | | | | | | | | | | | | | | | | | | | | | | | | | |
| T | O | | | | | | | | | | | | | | | | | | | | | | | | | | | | | | | | | | | | | | | | | | | | | | | | |
| 3 | 9 | | | | | | | | | | | | | | | | | | | | | | | | | | | | | | | | | | | | | | | | | | | | | | | | |
| + | 0 | | | | | | | | | | | | | | | | | | | | | | | | | | | | | | | | | | | | | | | | | | | | | | | | |
| 4 | 8 | | | | | | | | | | | | | | | | | | | | | | | | | | | | | | | | | | | | | | | | | | | | | | | | |
| T | O | | | | | | | | | | | | | | | | | | | | | | | | | | | | | | | | | | | | | | | | | | | | | | | | |
| 4 | 2 | | | | | | | | | | | | | | | | | | | | | | | | | | | | | | | | | | | | | | | | | | | | | | | | |
| + | 2 | | | | | | | | | | | | | | | | | | | | | | | | | | | | | | | | | | | | | | | | | | | | | | | | |
| 7 | 0 | | | | | | | | | | | | | | | | | | | | | | | | | | | | | | | | | | | | | | | | | | | | | | | | |
| 6. | <table border="1"><tr><th>T</th><th>O</th></tr><tr><td>3</td><td>1</td></tr><tr><td>+</td><td>4</td></tr><tr><td>8</td><td>0</td></tr></table> | T | O | 3 | 1 | + | 4 | 8 | 0 | 7. | <table border="1"><tr><th>T</th><th>O</th></tr><tr><td>4</td><td>3</td></tr><tr><td>+</td><td>2</td></tr><tr><td>7</td><td>2</td></tr></table> | T | O | 4 | 3 | + | 2 | 7 | 2 | 8. | <table border="1"><tr><th>T</th><th>O</th></tr><tr><td>1</td><td>8</td></tr><tr><td>+</td><td>1</td></tr><tr><td>3</td><td>3</td></tr></table> | T | O | 1 | 8 | + | 1 | 3 | 3 | 9. | <table border="1"><tr><th>T</th><th>O</th></tr><tr><td>4</td><td>2</td></tr><tr><td>+</td><td>1</td></tr><tr><td>6</td><td>1</td></tr></table> | T | O | 4 | 2 | + | 1 | 6 | 1 | 10. | <table border="1"><tr><th>T</th><th>O</th></tr><tr><td>3</td><td>5</td></tr><tr><td>+</td><td>4</td></tr><tr><td>8</td><td>1</td></tr></table> | T | O | 3 | 5 | + | 4 | 8 | 1 |
| T | O | | | | | | | | | | | | | | | | | | | | | | | | | | | | | | | | | | | | | | | | | | | | | | | | |
| 3 | 1 | | | | | | | | | | | | | | | | | | | | | | | | | | | | | | | | | | | | | | | | | | | | | | | | |
| + | 4 | | | | | | | | | | | | | | | | | | | | | | | | | | | | | | | | | | | | | | | | | | | | | | | | |
| 8 | 0 | | | | | | | | | | | | | | | | | | | | | | | | | | | | | | | | | | | | | | | | | | | | | | | | |
| T | O | | | | | | | | | | | | | | | | | | | | | | | | | | | | | | | | | | | | | | | | | | | | | | | | |
| 4 | 3 | | | | | | | | | | | | | | | | | | | | | | | | | | | | | | | | | | | | | | | | | | | | | | | | |
| + | 2 | | | | | | | | | | | | | | | | | | | | | | | | | | | | | | | | | | | | | | | | | | | | | | | | |
| 7 | 2 | | | | | | | | | | | | | | | | | | | | | | | | | | | | | | | | | | | | | | | | | | | | | | | | |
| T | O | | | | | | | | | | | | | | | | | | | | | | | | | | | | | | | | | | | | | | | | | | | | | | | | |
| 1 | 8 | | | | | | | | | | | | | | | | | | | | | | | | | | | | | | | | | | | | | | | | | | | | | | | | |
| + | 1 | | | | | | | | | | | | | | | | | | | | | | | | | | | | | | | | | | | | | | | | | | | | | | | | |
| 3 | 3 | | | | | | | | | | | | | | | | | | | | | | | | | | | | | | | | | | | | | | | | | | | | | | | | |
| T | O | | | | | | | | | | | | | | | | | | | | | | | | | | | | | | | | | | | | | | | | | | | | | | | | |
| 4 | 2 | | | | | | | | | | | | | | | | | | | | | | | | | | | | | | | | | | | | | | | | | | | | | | | | |
| + | 1 | | | | | | | | | | | | | | | | | | | | | | | | | | | | | | | | | | | | | | | | | | | | | | | | |
| 6 | 1 | | | | | | | | | | | | | | | | | | | | | | | | | | | | | | | | | | | | | | | | | | | | | | | | |
| T | O | | | | | | | | | | | | | | | | | | | | | | | | | | | | | | | | | | | | | | | | | | | | | | | | |
| 3 | 5 | | | | | | | | | | | | | | | | | | | | | | | | | | | | | | | | | | | | | | | | | | | | | | | | |
| + | 4 | | | | | | | | | | | | | | | | | | | | | | | | | | | | | | | | | | | | | | | | | | | | | | | | |
| 8 | 1 | | | | | | | | | | | | | | | | | | | | | | | | | | | | | | | | | | | | | | | | | | | | | | | | |
| 11. | <table border="1"><tr><th>T</th><th>O</th></tr><tr><td>4</td><td>5</td></tr><tr><td>+</td><td>3</td></tr><tr><td>8</td><td>3</td></tr></table> | T | O | 4 | 5 | + | 3 | 8 | 3 | 12. | <table border="1"><tr><th>T</th><th>O</th></tr><tr><td>6</td><td>8</td></tr><tr><td>+</td><td>2</td></tr><tr><td>9</td><td>5</td></tr></table> | T | O | 6 | 8 | + | 2 | 9 | 5 | 13. | <table border="1"><tr><th>T</th><th>O</th></tr><tr><td>6</td><td>7</td></tr><tr><td>+</td><td>1</td></tr><tr><td>8</td><td>6</td></tr></table> | T | O | 6 | 7 | + | 1 | 8 | 6 | 14. | <table border="1"><tr><th>T</th><th>O</th></tr><tr><td>7</td><td>6</td></tr><tr><td>+</td><td>1</td></tr><tr><td>9</td><td>4</td></tr></table> | T | O | 7 | 6 | + | 1 | 9 | 4 | 15. | <table border="1"><tr><th>T</th><th>O</th></tr><tr><td>5</td><td>8</td></tr><tr><td>+</td><td>3</td></tr><tr><td>9</td><td>6</td></tr></table> | T | O | 5 | 8 | + | 3 | 9 | 6 |
| T | O | | | | | | | | | | | | | | | | | | | | | | | | | | | | | | | | | | | | | | | | | | | | | | | | |
| 4 | 5 | | | | | | | | | | | | | | | | | | | | | | | | | | | | | | | | | | | | | | | | | | | | | | | | |
| + | 3 | | | | | | | | | | | | | | | | | | | | | | | | | | | | | | | | | | | | | | | | | | | | | | | | |
| 8 | 3 | | | | | | | | | | | | | | | | | | | | | | | | | | | | | | | | | | | | | | | | | | | | | | | | |
| T | O | | | | | | | | | | | | | | | | | | | | | | | | | | | | | | | | | | | | | | | | | | | | | | | | |
| 6 | 8 | | | | | | | | | | | | | | | | | | | | | | | | | | | | | | | | | | | | | | | | | | | | | | | | |
| + | 2 | | | | | | | | | | | | | | | | | | | | | | | | | | | | | | | | | | | | | | | | | | | | | | | | |
| 9 | 5 | | | | | | | | | | | | | | | | | | | | | | | | | | | | | | | | | | | | | | | | | | | | | | | | |
| T | O | | | | | | | | | | | | | | | | | | | | | | | | | | | | | | | | | | | | | | | | | | | | | | | | |
| 6 | 7 | | | | | | | | | | | | | | | | | | | | | | | | | | | | | | | | | | | | | | | | | | | | | | | | |
| + | 1 | | | | | | | | | | | | | | | | | | | | | | | | | | | | | | | | | | | | | | | | | | | | | | | | |
| 8 | 6 | | | | | | | | | | | | | | | | | | | | | | | | | | | | | | | | | | | | | | | | | | | | | | | | |
| T | O | | | | | | | | | | | | | | | | | | | | | | | | | | | | | | | | | | | | | | | | | | | | | | | | |
| 7 | 6 | | | | | | | | | | | | | | | | | | | | | | | | | | | | | | | | | | | | | | | | | | | | | | | | |
| + | 1 | | | | | | | | | | | | | | | | | | | | | | | | | | | | | | | | | | | | | | | | | | | | | | | | |
| 9 | 4 | | | | | | | | | | | | | | | | | | | | | | | | | | | | | | | | | | | | | | | | | | | | | | | | |
| T | O | | | | | | | | | | | | | | | | | | | | | | | | | | | | | | | | | | | | | | | | | | | | | | | | |
| 5 | 8 | | | | | | | | | | | | | | | | | | | | | | | | | | | | | | | | | | | | | | | | | | | | | | | | |
| + | 3 | | | | | | | | | | | | | | | | | | | | | | | | | | | | | | | | | | | | | | | | | | | | | | | | |
| 9 | 6 | | | | | | | | | | | | | | | | | | | | | | | | | | | | | | | | | | | | | | | | | | | | | | | | |





Quick Response 2.5

Add the following.

- | | | | | | | | | | | | | | | | | | | | | | | | | | | | | | | | | | | | | | | | | | | | | | | | | | | | | | | | | | | | | | | | | |
|-----|---|---|---|---|---|---|---|---|---|---|---|---|-----|--|---|---|---|---|---|---|---|---|---|----|---|-----|---|---|---|---|---|---|---|---|---|---|---|---|-----|---|---|---|---|---|---|---|---|---|---|---|---|-----|---|---|---|---|---|---|---|---|---|---|---|---|
| 1. | <table border="1"><tr><td>T</td><td>O</td></tr><tr><td>2</td><td>3</td></tr><tr><td>1</td><td>4</td></tr><tr><td>+</td><td>2</td><td>5</td></tr><tr><td>6</td><td>2</td></tr></table> | T | O | 2 | 3 | 1 | 4 | + | 2 | 5 | 6 | 2 | 2. | <table border="1"><tr><td>T</td><td>O</td></tr><tr><td>3</td><td>8</td></tr><tr><td>1</td><td>0</td></tr><tr><td>+</td><td>1</td><td>8</td></tr><tr><td>6</td><td>6</td></tr></table> | T | O | 3 | 8 | 1 | 0 | + | 1 | 8 | 6 | 6 | 3. | <table border="1"><tr><td>T</td><td>O</td></tr><tr><td>1</td><td>2</td></tr><tr><td>2</td><td>3</td></tr><tr><td>+</td><td>4</td><td>8</td></tr><tr><td>8</td><td>3</td></tr></table> | T | O | 1 | 2 | 2 | 3 | + | 4 | 8 | 8 | 3 | 4. | <table border="1"><tr><td>T</td><td>O</td></tr><tr><td>2</td><td>3</td></tr><tr><td>1</td><td>5</td></tr><tr><td>+</td><td>3</td><td>7</td></tr><tr><td>7</td><td>5</td></tr></table> | T | O | 2 | 3 | 1 | 5 | + | 3 | 7 | 7 | 5 | 5. | <table border="1"><tr><td>T</td><td>O</td></tr><tr><td>4</td><td>5</td></tr><tr><td>0</td><td>2</td></tr><tr><td>+</td><td>3</td><td>8</td></tr><tr><td>8</td><td>5</td></tr></table> | T | O | 4 | 5 | 0 | 2 | + | 3 | 8 | 8 | 5 |
| T | O | | | | | | | | | | | | | | | | | | | | | | | | | | | | | | | | | | | | | | | | | | | | | | | | | | | | | | | | | | | | | | | |
| 2 | 3 | | | | | | | | | | | | | | | | | | | | | | | | | | | | | | | | | | | | | | | | | | | | | | | | | | | | | | | | | | | | | | | |
| 1 | 4 | | | | | | | | | | | | | | | | | | | | | | | | | | | | | | | | | | | | | | | | | | | | | | | | | | | | | | | | | | | | | | | |
| + | 2 | 5 | | | | | | | | | | | | | | | | | | | | | | | | | | | | | | | | | | | | | | | | | | | | | | | | | | | | | | | | | | | | | | |
| 6 | 2 | | | | | | | | | | | | | | | | | | | | | | | | | | | | | | | | | | | | | | | | | | | | | | | | | | | | | | | | | | | | | | | |
| T | O | | | | | | | | | | | | | | | | | | | | | | | | | | | | | | | | | | | | | | | | | | | | | | | | | | | | | | | | | | | | | | | |
| 3 | 8 | | | | | | | | | | | | | | | | | | | | | | | | | | | | | | | | | | | | | | | | | | | | | | | | | | | | | | | | | | | | | | | |
| 1 | 0 | | | | | | | | | | | | | | | | | | | | | | | | | | | | | | | | | | | | | | | | | | | | | | | | | | | | | | | | | | | | | | | |
| + | 1 | 8 | | | | | | | | | | | | | | | | | | | | | | | | | | | | | | | | | | | | | | | | | | | | | | | | | | | | | | | | | | | | | | |
| 6 | 6 | | | | | | | | | | | | | | | | | | | | | | | | | | | | | | | | | | | | | | | | | | | | | | | | | | | | | | | | | | | | | | | |
| T | O | | | | | | | | | | | | | | | | | | | | | | | | | | | | | | | | | | | | | | | | | | | | | | | | | | | | | | | | | | | | | | | |
| 1 | 2 | | | | | | | | | | | | | | | | | | | | | | | | | | | | | | | | | | | | | | | | | | | | | | | | | | | | | | | | | | | | | | | |
| 2 | 3 | | | | | | | | | | | | | | | | | | | | | | | | | | | | | | | | | | | | | | | | | | | | | | | | | | | | | | | | | | | | | | | |
| + | 4 | 8 | | | | | | | | | | | | | | | | | | | | | | | | | | | | | | | | | | | | | | | | | | | | | | | | | | | | | | | | | | | | | | |
| 8 | 3 | | | | | | | | | | | | | | | | | | | | | | | | | | | | | | | | | | | | | | | | | | | | | | | | | | | | | | | | | | | | | | | |
| T | O | | | | | | | | | | | | | | | | | | | | | | | | | | | | | | | | | | | | | | | | | | | | | | | | | | | | | | | | | | | | | | | |
| 2 | 3 | | | | | | | | | | | | | | | | | | | | | | | | | | | | | | | | | | | | | | | | | | | | | | | | | | | | | | | | | | | | | | | |
| 1 | 5 | | | | | | | | | | | | | | | | | | | | | | | | | | | | | | | | | | | | | | | | | | | | | | | | | | | | | | | | | | | | | | | |
| + | 3 | 7 | | | | | | | | | | | | | | | | | | | | | | | | | | | | | | | | | | | | | | | | | | | | | | | | | | | | | | | | | | | | | | |
| 7 | 5 | | | | | | | | | | | | | | | | | | | | | | | | | | | | | | | | | | | | | | | | | | | | | | | | | | | | | | | | | | | | | | | |
| T | O | | | | | | | | | | | | | | | | | | | | | | | | | | | | | | | | | | | | | | | | | | | | | | | | | | | | | | | | | | | | | | | |
| 4 | 5 | | | | | | | | | | | | | | | | | | | | | | | | | | | | | | | | | | | | | | | | | | | | | | | | | | | | | | | | | | | | | | | |
| 0 | 2 | | | | | | | | | | | | | | | | | | | | | | | | | | | | | | | | | | | | | | | | | | | | | | | | | | | | | | | | | | | | | | | |
| + | 3 | 8 | | | | | | | | | | | | | | | | | | | | | | | | | | | | | | | | | | | | | | | | | | | | | | | | | | | | | | | | | | | | | | |
| 8 | 5 | | | | | | | | | | | | | | | | | | | | | | | | | | | | | | | | | | | | | | | | | | | | | | | | | | | | | | | | | | | | | | | |
| 6. | <table border="1"><tr><td>T</td><td>O</td></tr><tr><td>4</td><td>2</td></tr><tr><td>1</td><td>2</td></tr><tr><td>+</td><td>2</td><td>8</td></tr><tr><td>8</td><td>2</td></tr></table> | T | O | 4 | 2 | 1 | 2 | + | 2 | 8 | 8 | 2 | 7. | <table border="1"><tr><td>T</td><td>O</td></tr><tr><td>2</td><td>0</td></tr><tr><td>2</td><td>7</td></tr><tr><td>+</td><td>5</td><td>8</td></tr><tr><td>10</td><td>5</td></tr></table> | T | O | 2 | 0 | 2 | 7 | + | 5 | 8 | 10 | 5 | 8. | <table border="1"><tr><td>T</td><td>O</td></tr><tr><td>2</td><td>2</td></tr><tr><td>2</td><td>4</td></tr><tr><td>+</td><td>2</td><td>4</td></tr><tr><td>7</td><td>0</td></tr></table> | T | O | 2 | 2 | 2 | 4 | + | 2 | 4 | 7 | 0 | 9. | <table border="1"><tr><td>T</td><td>O</td></tr><tr><td>3</td><td>2</td></tr><tr><td>3</td><td>5</td></tr><tr><td>+</td><td>0</td><td>6</td></tr><tr><td>7</td><td>3</td></tr></table> | T | O | 3 | 2 | 3 | 5 | + | 0 | 6 | 7 | 3 | 10. | <table border="1"><tr><td>T</td><td>O</td></tr><tr><td>1</td><td>7</td></tr><tr><td>2</td><td>8</td></tr><tr><td>+</td><td>3</td><td>9</td></tr><tr><td>8</td><td>4</td></tr></table> | T | O | 1 | 7 | 2 | 8 | + | 3 | 9 | 8 | 4 |
| T | O | | | | | | | | | | | | | | | | | | | | | | | | | | | | | | | | | | | | | | | | | | | | | | | | | | | | | | | | | | | | | | | |
| 4 | 2 | | | | | | | | | | | | | | | | | | | | | | | | | | | | | | | | | | | | | | | | | | | | | | | | | | | | | | | | | | | | | | | |
| 1 | 2 | | | | | | | | | | | | | | | | | | | | | | | | | | | | | | | | | | | | | | | | | | | | | | | | | | | | | | | | | | | | | | | |
| + | 2 | 8 | | | | | | | | | | | | | | | | | | | | | | | | | | | | | | | | | | | | | | | | | | | | | | | | | | | | | | | | | | | | | | |
| 8 | 2 | | | | | | | | | | | | | | | | | | | | | | | | | | | | | | | | | | | | | | | | | | | | | | | | | | | | | | | | | | | | | | | |
| T | O | | | | | | | | | | | | | | | | | | | | | | | | | | | | | | | | | | | | | | | | | | | | | | | | | | | | | | | | | | | | | | | |
| 2 | 0 | | | | | | | | | | | | | | | | | | | | | | | | | | | | | | | | | | | | | | | | | | | | | | | | | | | | | | | | | | | | | | | |
| 2 | 7 | | | | | | | | | | | | | | | | | | | | | | | | | | | | | | | | | | | | | | | | | | | | | | | | | | | | | | | | | | | | | | | |
| + | 5 | 8 | | | | | | | | | | | | | | | | | | | | | | | | | | | | | | | | | | | | | | | | | | | | | | | | | | | | | | | | | | | | | | |
| 10 | 5 | | | | | | | | | | | | | | | | | | | | | | | | | | | | | | | | | | | | | | | | | | | | | | | | | | | | | | | | | | | | | | | |
| T | O | | | | | | | | | | | | | | | | | | | | | | | | | | | | | | | | | | | | | | | | | | | | | | | | | | | | | | | | | | | | | | | |
| 2 | 2 | | | | | | | | | | | | | | | | | | | | | | | | | | | | | | | | | | | | | | | | | | | | | | | | | | | | | | | | | | | | | | | |
| 2 | 4 | | | | | | | | | | | | | | | | | | | | | | | | | | | | | | | | | | | | | | | | | | | | | | | | | | | | | | | | | | | | | | | |
| + | 2 | 4 | | | | | | | | | | | | | | | | | | | | | | | | | | | | | | | | | | | | | | | | | | | | | | | | | | | | | | | | | | | | | | |
| 7 | 0 | | | | | | | | | | | | | | | | | | | | | | | | | | | | | | | | | | | | | | | | | | | | | | | | | | | | | | | | | | | | | | | |
| T | O | | | | | | | | | | | | | | | | | | | | | | | | | | | | | | | | | | | | | | | | | | | | | | | | | | | | | | | | | | | | | | | |
| 3 | 2 | | | | | | | | | | | | | | | | | | | | | | | | | | | | | | | | | | | | | | | | | | | | | | | | | | | | | | | | | | | | | | | |
| 3 | 5 | | | | | | | | | | | | | | | | | | | | | | | | | | | | | | | | | | | | | | | | | | | | | | | | | | | | | | | | | | | | | | | |
| + | 0 | 6 | | | | | | | | | | | | | | | | | | | | | | | | | | | | | | | | | | | | | | | | | | | | | | | | | | | | | | | | | | | | | | |
| 7 | 3 | | | | | | | | | | | | | | | | | | | | | | | | | | | | | | | | | | | | | | | | | | | | | | | | | | | | | | | | | | | | | | | |
| T | O | | | | | | | | | | | | | | | | | | | | | | | | | | | | | | | | | | | | | | | | | | | | | | | | | | | | | | | | | | | | | | | |
| 1 | 7 | | | | | | | | | | | | | | | | | | | | | | | | | | | | | | | | | | | | | | | | | | | | | | | | | | | | | | | | | | | | | | | |
| 2 | 8 | | | | | | | | | | | | | | | | | | | | | | | | | | | | | | | | | | | | | | | | | | | | | | | | | | | | | | | | | | | | | | | |
| + | 3 | 9 | | | | | | | | | | | | | | | | | | | | | | | | | | | | | | | | | | | | | | | | | | | | | | | | | | | | | | | | | | | | | | |
| 8 | 4 | | | | | | | | | | | | | | | | | | | | | | | | | | | | | | | | | | | | | | | | | | | | | | | | | | | | | | | | | | | | | | | |
| 11. | <table border="1"><tr><td>T</td><td>O</td></tr><tr><td>2</td><td>9</td></tr><tr><td>1</td><td>8</td></tr><tr><td>+</td><td>3</td><td>4</td></tr><tr><td>8</td><td>1</td></tr></table> | T | O | 2 | 9 | 1 | 8 | + | 3 | 4 | 8 | 1 | 12. | <table border="1"><tr><td>T</td><td>O</td></tr><tr><td>1</td><td>5</td></tr><tr><td>2</td><td>7</td></tr><tr><td>+</td><td>3</td><td>6</td></tr><tr><td>7</td><td>8</td></tr></table> | T | O | 1 | 5 | 2 | 7 | + | 3 | 6 | 7 | 8 | 13. | <table border="1"><tr><td>T</td><td>O</td></tr><tr><td>5</td><td>6</td></tr><tr><td>1</td><td>4</td></tr><tr><td>+</td><td>2</td><td>6</td></tr><tr><td>9</td><td>6</td></tr></table> | T | O | 5 | 6 | 1 | 4 | + | 2 | 6 | 9 | 6 | 14. | <table border="1"><tr><td>T</td><td>O</td></tr><tr><td>3</td><td>4</td></tr><tr><td>1</td><td>7</td></tr><tr><td>+</td><td>2</td><td>8</td></tr><tr><td>7</td><td>9</td></tr></table> | T | O | 3 | 4 | 1 | 7 | + | 2 | 8 | 7 | 9 | 15. | <table border="1"><tr><td>T</td><td>O</td></tr><tr><td>4</td><td>5</td></tr><tr><td>1</td><td>6</td></tr><tr><td>+</td><td>2</td><td>9</td></tr><tr><td>9</td><td>0</td></tr></table> | T | O | 4 | 5 | 1 | 6 | + | 2 | 9 | 9 | 0 |
| T | O | | | | | | | | | | | | | | | | | | | | | | | | | | | | | | | | | | | | | | | | | | | | | | | | | | | | | | | | | | | | | | | |
| 2 | 9 | | | | | | | | | | | | | | | | | | | | | | | | | | | | | | | | | | | | | | | | | | | | | | | | | | | | | | | | | | | | | | | |
| 1 | 8 | | | | | | | | | | | | | | | | | | | | | | | | | | | | | | | | | | | | | | | | | | | | | | | | | | | | | | | | | | | | | | | |
| + | 3 | 4 | | | | | | | | | | | | | | | | | | | | | | | | | | | | | | | | | | | | | | | | | | | | | | | | | | | | | | | | | | | | | | |
| 8 | 1 | | | | | | | | | | | | | | | | | | | | | | | | | | | | | | | | | | | | | | | | | | | | | | | | | | | | | | | | | | | | | | | |
| T | O | | | | | | | | | | | | | | | | | | | | | | | | | | | | | | | | | | | | | | | | | | | | | | | | | | | | | | | | | | | | | | | |
| 1 | 5 | | | | | | | | | | | | | | | | | | | | | | | | | | | | | | | | | | | | | | | | | | | | | | | | | | | | | | | | | | | | | | | |
| 2 | 7 | | | | | | | | | | | | | | | | | | | | | | | | | | | | | | | | | | | | | | | | | | | | | | | | | | | | | | | | | | | | | | | |
| + | 3 | 6 | | | | | | | | | | | | | | | | | | | | | | | | | | | | | | | | | | | | | | | | | | | | | | | | | | | | | | | | | | | | | | |
| 7 | 8 | | | | | | | | | | | | | | | | | | | | | | | | | | | | | | | | | | | | | | | | | | | | | | | | | | | | | | | | | | | | | | | |
| T | O | | | | | | | | | | | | | | | | | | | | | | | | | | | | | | | | | | | | | | | | | | | | | | | | | | | | | | | | | | | | | | | |
| 5 | 6 | | | | | | | | | | | | | | | | | | | | | | | | | | | | | | | | | | | | | | | | | | | | | | | | | | | | | | | | | | | | | | | |
| 1 | 4 | | | | | | | | | | | | | | | | | | | | | | | | | | | | | | | | | | | | | | | | | | | | | | | | | | | | | | | | | | | | | | | |
| + | 2 | 6 | | | | | | | | | | | | | | | | | | | | | | | | | | | | | | | | | | | | | | | | | | | | | | | | | | | | | | | | | | | | | | |
| 9 | 6 | | | | | | | | | | | | | | | | | | | | | | | | | | | | | | | | | | | | | | | | | | | | | | | | | | | | | | | | | | | | | | | |
| T | O | | | | | | | | | | | | | | | | | | | | | | | | | | | | | | | | | | | | | | | | | | | | | | | | | | | | | | | | | | | | | | | |
| 3 | 4 | | | | | | | | | | | | | | | | | | | | | | | | | | | | | | | | | | | | | | | | | | | | | | | | | | | | | | | | | | | | | | | |
| 1 | 7 | | | | | | | | | | | | | | | | | | | | | | | | | | | | | | | | | | | | | | | | | | | | | | | | | | | | | | | | | | | | | | | |
| + | 2 | 8 | | | | | | | | | | | | | | | | | | | | | | | | | | | | | | | | | | | | | | | | | | | | | | | | | | | | | | | | | | | | | | |
| 7 | 9 | | | | | | | | | | | | | | | | | | | | | | | | | | | | | | | | | | | | | | | | | | | | | | | | | | | | | | | | | | | | | | | |
| T | O | | | | | | | | | | | | | | | | | | | | | | | | | | | | | | | | | | | | | | | | | | | | | | | | | | | | | | | | | | | | | | | |
| 4 | 5 | | | | | | | | | | | | | | | | | | | | | | | | | | | | | | | | | | | | | | | | | | | | | | | | | | | | | | | | | | | | | | | |
| 1 | 6 | | | | | | | | | | | | | | | | | | | | | | | | | | | | | | | | | | | | | | | | | | | | | | | | | | | | | | | | | | | | | | | |
| + | 2 | 9 | | | | | | | | | | | | | | | | | | | | | | | | | | | | | | | | | | | | | | | | | | | | | | | | | | | | | | | | | | | | | | |
| 9 | 0 | | | | | | | | | | | | | | | | | | | | | | | | | | | | | | | | | | | | | | | | | | | | | | | | | | | | | | | | | | | | | | | |



Quick Response 2.6

Solve the following.

- There are 32 roses and 34 tulips in a garden. How many flowers are there in the garden altogether?
- There are 33 girls and 34 boys in a class. How many students are there in the class altogether?
- Amrit collected 62 red marbles and 26 blue marbles. How many marbles does Amrit have in all?

$$\begin{array}{|c|c|} \hline 3 & 2 \\ \hline + & 3 & 4 \\ \hline 6 & 6 \\ \hline \end{array}$$

$$\begin{array}{|c|c|} \hline 3 & 3 \\ \hline + & 3 & 4 \\ \hline 6 & 7 \\ \hline \end{array}$$

$$\begin{array}{|c|c|} \hline 6 & 2 \\ \hline + & 2 & 6 \\ \hline 8 & 8 \\ \hline \end{array}$$



4. A shopkeeper sold 43 toffees in the morning and 34 toffees in the evening. How many toffees did he sell in all?

4	3
3	4
7	7

5. In a party, there were 54 vegetarians and 45 non-vegetarians. How many people were there in the party altogether?

5	4
4	5
9	9

PMP





Chapter Review

1. Add the following without carry over.

$$\begin{array}{|c|c|} \hline \text{T} & \text{O} \\ \hline 2 & 4 \\ \hline + & 3 & 2 \\ \hline 5 & 6 \\ \hline \end{array}$$

$$\begin{array}{|c|c|} \hline \text{T} & \text{O} \\ \hline 4 & 3 \\ \hline + & 2 & 4 \\ \hline 6 & 7 \\ \hline \end{array}$$

$$\begin{array}{|c|c|} \hline \text{T} & \text{O} \\ \hline 3 & 1 \\ \hline + & 5 & 0 \\ \hline 8 & 1 \\ \hline \end{array}$$

$$\begin{array}{|c|c|} \hline \text{T} & \text{O} \\ \hline 5 & 4 \\ \hline + & 4 & 3 \\ \hline 9 & 7 \\ \hline \end{array}$$

2. Regroup the following.

a) 2 tens 15 ones = 3 tens 5 ones

b) 4 tens 10 ones = 5 tens 0 ones

c) 5 tens 12 ones = 6 tens 2 ones

d) 6 tens 18 ones = 7 tens 8 ones

3. Add the following with carry over.

$$\begin{array}{|c|c|} \hline \text{T} & \text{O} \\ \hline 3 & 4 \\ \hline + & 2 & 7 \\ \hline 6 & 1 \\ \hline \end{array}$$

$$\begin{array}{|c|c|} \hline \text{T} & \text{O} \\ \hline 3 & 3 \\ \hline + & 4 & 8 \\ \hline 8 & 1 \\ \hline \end{array}$$

$$\begin{array}{|c|c|} \hline \text{T} & \text{O} \\ \hline 5 & 5 \\ \hline + & 1 & 7 \\ \hline 7 & 2 \\ \hline \end{array}$$

$$\begin{array}{|c|c|} \hline \text{T} & \text{O} \\ \hline 4 & 8 \\ \hline + & 2 & 9 \\ \hline 7 & 7 \\ \hline \end{array}$$

$$\begin{array}{|c|c|} \hline \text{T} & \text{O} \\ \hline 2 & 5 \\ \hline 4 & 3 \\ \hline + & 2 & 4 \\ \hline 9 & 2 \\ \hline \end{array}$$

$$\begin{array}{|c|c|} \hline \text{T} & \text{O} \\ \hline 3 & 3 \\ \hline 2 & 4 \\ \hline + & 1 & 7 \\ \hline 7 & 4 \\ \hline \end{array}$$

$$\begin{array}{|c|c|} \hline \text{T} & \text{O} \\ \hline 2 & 2 \\ \hline 1 & 8 \\ \hline + & 1 & 5 \\ \hline 5 & 5 \\ \hline \end{array}$$

$$\begin{array}{|c|c|} \hline \text{T} & \text{O} \\ \hline 1 & 3 \\ \hline 2 & 6 \\ \hline + & 2 & 5 \\ \hline 6 & 4 \\ \hline \end{array}$$

4. There are 36 men and 42 women in a bus. How many people are altogether in the bus?

$$\begin{array}{|c|c|} \hline 3 & 6 \\ \hline + & 4 & 2 \\ \hline 7 & 8 \\ \hline \end{array}$$



Critical Thinking

1. Observe the pattern and fill in the blank circles.

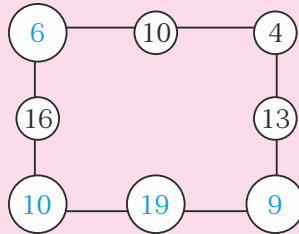
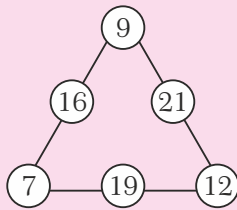

2. Choose two numbers from the box the sum of which is:

a) $50 = \underline{\quad 23 \quad} + \underline{\quad 27 \quad}$

b) $95 = \underline{\quad 40 \quad} + \underline{\quad 55 \quad}$

50	40	28	35
23	36	55	27

Cross Curricular

Three boats participated in a boat race in Kerala on a very popular festival. If 24 people were in first boat, 21 people in the second and 23 people in the third boat, how many people participated in all the three boats? Also, name the festival.

Ans. Total peoples participated in all the three boats:

$$24 + 21 + 23 = 68$$

Festival name is Pongal.

SDG

Sajal, Dipti and Razia planted 24, 15 and 26 saplings in their compound, respectively, to make their compounds look beautiful.

How many saplings did they plant altogether? 65

What do plants give us? Plants give us oxygen, food and many other useful things.



3

Subtraction



Get Ready

1. Subtract the following on the number line.

a) $15 - 4 = 11$

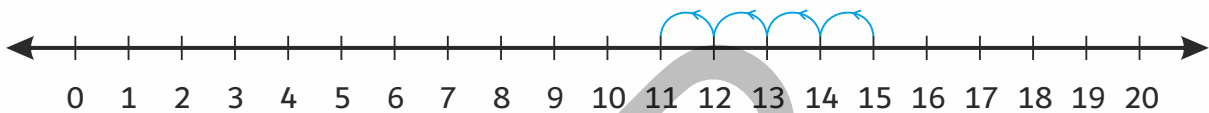

b) $18 - 7 = 11$

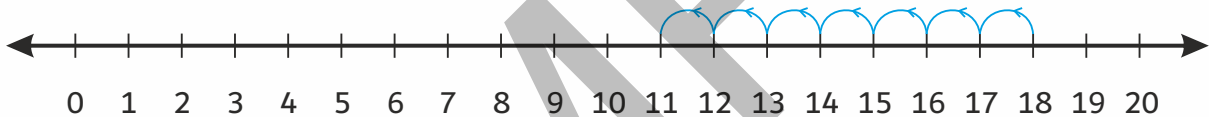

2. Subtract the following (without borrowing).

a)

T	O
5	6
-	2
3	3

b)

T	O
8	8
-	4
4	5

c)

T	O
5	9
-	3
2	2

d)

T	O
8	5
-	5
3	3



3. Subtract the following (with borrowing).

a)

T	O
5	2
-	3
1	8

b)

T	O
4	0
-	2
1	5

c)

T	O
8	3
-	5
2	4

d)

T	O
9	4
-	4
4	8

4. There were 87 passengers in a bus. 34 of them got off the bus at the next stop. How many passengers are still in the bus?

8	7
-	3
5	3





Quick Response 3.1

Subtract the following.

- | | | | | | | | | | |
|-----|--|-----|--|-----|--|-----|--|-----|--|
| 1. | $\begin{array}{r} \text{T} \quad \text{O} \\ 5 \quad 7 \\ - 2 \quad 4 \\ \hline 3 \quad 3 \end{array}$ | 2. | $\begin{array}{r} \text{T} \quad \text{O} \\ 3 \quad 9 \\ - 1 \quad 0 \\ \hline 2 \quad 9 \end{array}$ | 3. | $\begin{array}{r} \text{T} \quad \text{O} \\ 4 \quad 8 \\ - 3 \quad 5 \\ \hline 1 \quad 3 \end{array}$ | 4. | $\begin{array}{r} \text{T} \quad \text{O} \\ 6 \quad 6 \\ - 3 \quad 3 \\ \hline 3 \quad 3 \end{array}$ | 5. | $\begin{array}{r} \text{T} \quad \text{O} \\ 6 \quad 9 \\ - 2 \quad 0 \\ \hline 4 \quad 9 \end{array}$ |
| 6. | $\begin{array}{r} \text{T} \quad \text{O} \\ 7 \quad 5 \\ - 3 \quad 4 \\ \hline 4 \quad 1 \end{array}$ | 7. | $\begin{array}{r} \text{T} \quad \text{O} \\ 5 \quad 9 \\ - 3 \quad 6 \\ \hline 2 \quad 3 \end{array}$ | 8. | $\begin{array}{r} \text{T} \quad \text{O} \\ 2 \quad 8 \\ - 1 \quad 8 \\ \hline 1 \quad 0 \end{array}$ | 9. | $\begin{array}{r} \text{T} \quad \text{O} \\ 6 \quad 4 \\ - 3 \quad 2 \\ \hline 3 \quad 2 \end{array}$ | 10. | $\begin{array}{r} \text{T} \quad \text{O} \\ 8 \quad 3 \\ - 5 \quad 1 \\ \hline 3 \quad 2 \end{array}$ |
| 11. | $\begin{array}{r} \text{T} \quad \text{O} \\ 8 \quad 8 \\ - 5 \quad 0 \\ \hline 3 \quad 8 \end{array}$ | 12. | $\begin{array}{r} \text{T} \quad \text{O} \\ 7 \quad 2 \\ - 6 \quad 1 \\ \hline 1 \quad 1 \end{array}$ | 13. | $\begin{array}{r} \text{T} \quad \text{O} \\ 9 \quad 8 \\ - 5 \quad 4 \\ \hline 4 \quad 4 \end{array}$ | 14. | $\begin{array}{r} \text{T} \quad \text{O} \\ 9 \quad 6 \\ - 0 \quad 5 \\ \hline 9 \quad 1 \end{array}$ | 15. | $\begin{array}{r} \text{T} \quad \text{O} \\ 8 \quad 7 \\ - 6 \quad 7 \\ \hline 2 \quad 0 \end{array}$ |



Quick Response 3.2

Fill in the boxes.

1. $7 - 1 = \boxed{6}$

2. $25 - 1 = \boxed{24}$

3. $38 - 0 = \boxed{38}$

4. $77 - 77 = \boxed{0}$

5. $98 - 1 = \boxed{97}$

6. $11 - 11 = \boxed{0}$

7. $55 - 1 = \boxed{54}$

8. $64 - 64 = \boxed{0}$

9. $81 - 0 = \boxed{81}$

10. $93 - 93 = \boxed{0}$





Quick Response 3.3

Subtract the following. Borrow if required.

- | | | |
|----|---|---|
| 1. | T | O |
| | 5 | 3 |
| - | 2 | 6 |
| | 2 | 7 |
- | | | |
|----|---|---|
| 2. | T | O |
| | 4 | 4 |
| - | 1 | 7 |
| | 2 | 7 |
- | | | |
|----|---|---|
| 3. | T | O |
| | 5 | 4 |
| - | 0 | 8 |
| | 4 | 6 |
- | | | |
|----|---|---|
| 4. | T | O |
| | 6 | 0 |
| - | 3 | 5 |
| | 2 | 5 |
- | | | |
|----|---|---|
| 5. | T | O |
| | 7 | 6 |
| - | 3 | 8 |
| | 3 | 8 |
-
- | | | |
|----|---|---|
| 6. | T | O |
| | 5 | 7 |
| - | 4 | 8 |
| | 0 | 9 |
- | | | |
|----|---|---|
| 7. | T | O |
| | 6 | 2 |
| - | 4 | 5 |
| | 1 | 7 |
- | | | |
|----|---|---|
| 8. | T | O |
| | 7 | 3 |
| - | 4 | 6 |
| | 2 | 7 |
- | | | |
|----|---|---|
| 9. | T | O |
| | 2 | 7 |
| - | 1 | 8 |
| | 0 | 9 |
- | | | |
|-----|---|---|
| 10. | T | O |
| | 4 | 8 |
| - | 1 | 9 |
| | 2 | 9 |
-
- | | | |
|-----|---|---|
| 11. | T | O |
| | 9 | 2 |
| - | 4 | 6 |
| | 4 | 6 |
- | | | |
|-----|---|---|
| 12. | T | O |
| | 8 | 4 |
| - | 4 | 8 |
| | 3 | 6 |
- | | | |
|-----|---|---|
| 13. | T | O |
| | 7 | 7 |
| - | 5 | 8 |
| | 1 | 9 |
- | | | |
|-----|---|---|
| 14. | T | O |
| | 9 | 2 |
| - | 7 | 6 |
| | 1 | 6 |
- | | | |
|-----|---|---|
| 15. | T | O |
| | 8 | 0 |
| - | 5 | 8 |
| | 2 | 2 |



Quick Response 3.4

Subtract and check the answers.

- | | | |
|----|---|---|
| 1. | T | O |
| | 8 | 4 |
| - | 3 | 7 |
| | 4 | 7 |
- | |
|---|
| → |
| + |
- | | |
|---|---|
| T | O |
| 4 | 7 |
| 3 | 7 |
| 8 | 4 |
- | | | |
|----|---|---|
| 2. | T | O |
| | 5 | 2 |
| - | 3 | 5 |
| | 1 | 7 |
- | |
|---|
| → |
| + |
- | | |
|---|---|
| T | O |
| 1 | 7 |
| 3 | 5 |
| 5 | 2 |
-
- | | | |
|----|---|---|
| 3. | T | O |
| | 9 | 6 |
| - | 5 | 8 |
| | 3 | 8 |
- | |
|---|
| → |
| + |
- | | |
|---|---|
| T | O |
| 3 | 8 |
| 5 | 8 |
| 9 | 6 |
- | | | |
|----|---|---|
| 4. | T | O |
| | 8 | 0 |
| - | 4 | 5 |
| | 3 | 5 |
- | |
|---|
| → |
| + |
- | | |
|---|---|
| T | O |
| 3 | 5 |
| 4 | 5 |
| 8 | 0 |

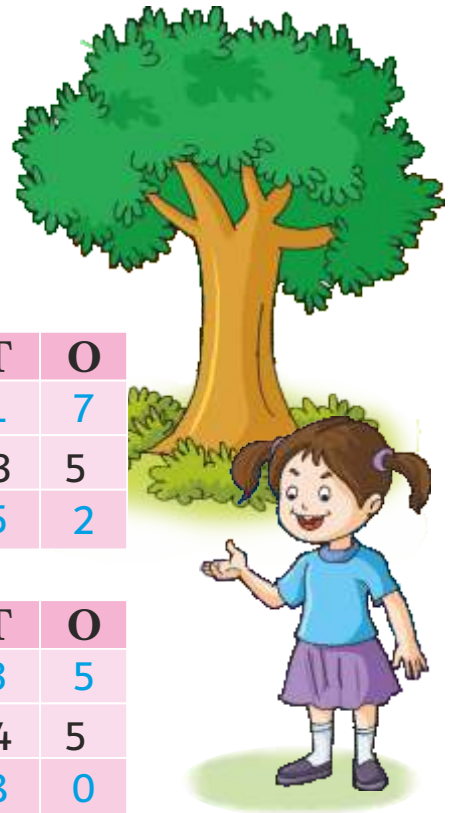



Quick Response 3.5

Solve the following.

1. There were 97 mangoes on a tree. A farmer plucked 32 mangoes. How many mangoes are still on the tree?

$$\begin{array}{r} 97 \\ - 32 \\ \hline 65 \end{array}$$

2. There are 56 students in a class. 26 of them are girls. How many boys are there in the class?

$$\begin{array}{r} 56 \\ - 26 \\ \hline 30 \end{array}$$

3. Priya invited 38 friends to her birthday party. But 14 of them could not attend the party. How many friends attended the party?

$$\begin{array}{r} 38 \\ - 14 \\ \hline 24 \end{array}$$

4. There were 83 birds sitting on a tree. 30 of them flew away. How many birds are still on the tree?

$$\begin{array}{r} 83 \\ - 30 \\ \hline 53 \end{array}$$

5. Rohit has 72 apples and his brother has 25 apples. How many more apples does Rohit have than his brother?

$$\begin{array}{r} 72 \\ - 25 \\ \hline 47 \end{array}$$

6. There are 92 pages in a book. Ananya has read only 30 pages. How many pages are left for Ananya to read?

$$\begin{array}{r} 92 \\ - 30 \\ \hline 62 \end{array}$$



7. Achin had 54 pebbles. He gave 22 of these to his friend. How many pebbles are left with Achin now?

$$\begin{array}{r} 54 \\ - 22 \\ \hline 32 \end{array}$$

8. An egg seller bought 65 eggs. On the way to his shop, 28 eggs broke. How many eggs does the egg seller have now?

$$\begin{array}{r} 65 \\ - 28 \\ \hline 37 \end{array}$$

9. There were 72 children in a park. 36 of them went to their homes. How many children were still in the park?

$$\begin{array}{r} 72 \\ - 36 \\ \hline 36 \end{array}$$

10. There were 80 fish in the lake. 44 of them were caught. How many fish are still in the lake?

$$\begin{array}{r} 80 \\ - 44 \\ \hline 36 \end{array}$$





Chapter Review

1. Subtract the following. (without regrouping)

$$\begin{array}{r} \text{T} \quad \text{O} \\ 5 \quad 7 \\ - 2 \quad 3 \\ \hline 3 \quad 4 \end{array}$$

$$\begin{array}{r} \text{T} \quad \text{O} \\ 6 \quad 9 \\ - 4 \quad 7 \\ \hline 2 \quad 2 \end{array}$$

$$\begin{array}{r} \text{T} \quad \text{O} \\ 8 \quad 8 \\ - 5 \quad 5 \\ \hline 3 \quad 3 \end{array}$$

$$\begin{array}{r} \text{T} \quad \text{O} \\ 9 \quad 4 \\ - 6 \quad 2 \\ \hline 3 \quad 2 \end{array}$$

2. Subtract the following. (with regrouping)

$$\begin{array}{r} \text{T} \quad \text{O} \\ 4 \quad 3 \\ - 2 \quad 6 \\ \hline 1 \quad 7 \end{array}$$

$$\begin{array}{r} \text{T} \quad \text{O} \\ 6 \quad 0 \\ - 3 \quad 7 \\ \hline 2 \quad 3 \end{array}$$

$$\begin{array}{r} \text{T} \quad \text{O} \\ 7 \quad 4 \\ - 4 \quad 6 \\ \hline 2 \quad 8 \end{array}$$

$$\begin{array}{r} \text{T} \quad \text{O} \\ 9 \quad 3 \\ - 6 \quad 5 \\ \hline 2 \quad 8 \end{array}$$

3. Subtract the following and check the answers.

$$\begin{array}{r} \text{T} \quad \text{O} \\ 5 \quad 4 \\ - 2 \quad 3 \\ \hline 3 \quad 1 \end{array} \quad \begin{array}{r} \text{T} \quad \text{O} \\ 3 \quad 1 \\ + 2 \quad 3 \\ \hline 5 \quad 4 \end{array}$$

$$\begin{array}{r} \text{T} \quad \text{O} \\ 5 \quad 8 \\ - 3 \quad 6 \\ \hline 2 \quad 2 \end{array} \quad \begin{array}{r} \text{T} \quad \text{O} \\ 2 \quad 2 \\ + 3 \quad 6 \\ \hline 5 \quad 8 \end{array}$$

$$\begin{array}{r} \text{T} \quad \text{O} \\ 9 \quad 2 \\ - 5 \quad 6 \\ \hline 3 \quad 6 \end{array} \quad \begin{array}{r} \text{T} \quad \text{O} \\ 3 \quad 6 \\ + 5 \quad 6 \\ \hline 9 \quad 2 \end{array}$$

$$\begin{array}{r} \text{T} \quad \text{O} \\ 8 \quad 2 \\ - 4 \quad 8 \\ \hline 3 \quad 4 \end{array} \quad \begin{array}{r} \text{T} \quad \text{O} \\ 3 \quad 4 \\ + 4 \quad 8 \\ \hline 8 \quad 2 \end{array}$$

4. Solve the following.

a) There are 56 students in a class. 26 of them are girls. How many boys are there in the class?

$$\begin{array}{r} 5 \quad 6 \\ - 2 \quad 6 \\ \hline 3 \quad 0 \end{array}$$

b) There were 84 passengers in a train coach. 32 of them got off at the next station. How many passengers are still in the coach?

$$\begin{array}{r} 8 \quad 4 \\ - 3 \quad 2 \\ \hline 5 \quad 2 \end{array}$$



1. Subtract 35 from 60 using the following method.

$$60 - 30 = 30, \quad 30 - 5 = 25$$

Now, solve the following using the above method.

a) $67 - 23 = 44$ b) $87 - 45 = 42$ c) $59 - 38 = 21$

d) $56 - 31 = 25$ e) $82 - 41 = 41$ f) $89 - 55 = 34$

2. Solve the following.

a) 2 tens less than 3 tens and 5 ones = 15

b) 10 ones less than 4 tens and 6 ones = 36

c) 1 ten and 4 ones less than 6 tens and 2 ones = 48

d) 2 tens and 6 ones less than 8 tens and 2 ones = 56

Tripti decided that she would save electricity. She knows that a lot of coal and money is used to produce electricity. By saving electricity, we can check pollution as well as save the money of our country.

In the previous month, Tripti's family had used 98 units of electricity. But this month, they have used only 76 units. How many units of electricity has her family saved? 22

Do you also save electricity? *Answer it yourself*

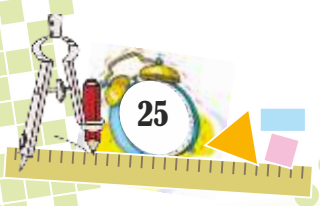

4

Multiplication



Get Ready

1. Write the following in multiplication form.

a) =

2 + 2 + 2

b) =

3 + 3 + 3 + 3

2. Write the following in repeated addition form.

a) $4 \times 2 = 2 + 2 + 2 + 2$

b) $5 \times 4 = 4 + 4 + 4 + 4 + 4$

3. Fill in the blanks.

a) $4 \times 2 = 8$ b) $3 \times 2 = 6$ c) $2 \times 5 = 10$

d) $5 \times 4 = 20$ e) $4 \times 6 = 24$ f) $3 \times 3 = 9$



4. Multiply.

a) $\begin{array}{r} 3 \\ \times 2 \\ \hline 6 \end{array}$ b) $\begin{array}{r} 4 \\ \times 3 \\ \hline 12 \end{array}$ c) $\begin{array}{r} 5 \\ \times 4 \\ \hline 20 \end{array}$ d) $\begin{array}{r} 6 \\ \times 3 \\ \hline 18 \end{array}$





Quick Response 4.1

1. Write the following in multiplication form.

- a) $4 + 4 + 4 + 4 + 4 = \underline{\quad 5 \times 4 \quad}$
- b) $6 + 6 + 6 + 6 + 6 = \underline{\quad 5 \times 6 \quad}$
- c) $8 + 8 + 8 + 8 + 8 + 8 = \underline{\quad 6 \times 8 \quad}$
- d) $9 + 9 + 9 = \underline{\quad 3 \times 9 \quad}$
- e) $10 + 10 + 10 + 10 + 10 + 10 = \underline{\quad 6 \times 10 \quad}$

2. Fill in the boxes.

- | | | |
|--|---|--|
| a) $7 \times 3 =$ <input type="text" value="21"/> | e) $4 \times 9 =$ <input type="text" value="36"/> | i) $9 \times 9 =$ <input type="text" value="81"/> |
| b) $8 \times 4 =$ <input type="text" value="32"/> | f) $5 \times 7 =$ <input type="text" value="35"/> | j) $10 \times 8 =$ <input type="text" value="80"/> |
| c) $5 \times 8 =$ <input type="text" value="40"/> | g) $8 \times 8 =$ <input type="text" value="64"/> | k) $6 \times 6 =$ <input type="text" value="36"/> |
| d) $10 \times 9 =$ <input type="text" value="90"/> | h) $7 \times 6 =$ <input type="text" value="42"/> | l) $10 \times 10 =$ <input type="text" value="100"/> |

3. Match the following.

a) 5×7	48	e) 9×5
b) 8×6	40	f) 10×4
c) 6×7	45	g) 9×8
d) 7×9	70	h) 10×7
	42	
	72	
	35	
	63	





Quick Response 4.2

Multiply.

1.
$$\begin{array}{r} 7 \\ \times 4 \\ \hline 28 \end{array}$$

2.
$$\begin{array}{r} 8 \\ \times 6 \\ \hline 48 \end{array}$$

3.
$$\begin{array}{r} 9 \\ \times 5 \\ \hline 45 \end{array}$$

4.
$$\begin{array}{r} 6 \\ \times 9 \\ \hline 54 \end{array}$$

5.
$$\begin{array}{r} 6 \\ \times 7 \\ \hline 42 \end{array}$$

6.
$$\begin{array}{r} 8 \\ \times 8 \\ \hline 64 \end{array}$$

7.
$$\begin{array}{r} 7 \\ \times 5 \\ \hline 35 \end{array}$$

8.
$$\begin{array}{r} 6 \\ \times 2 \\ \hline 12 \end{array}$$

9.
$$\begin{array}{r} 9 \\ \times 4 \\ \hline 36 \end{array}$$

10.
$$\begin{array}{r} 5 \\ \times 5 \\ \hline 25 \end{array}$$

11.
$$\begin{array}{r} 9 \\ \times 3 \\ \hline 27 \end{array}$$

12.
$$\begin{array}{r} 3 \\ \times 6 \\ \hline 18 \end{array}$$

13.
$$\begin{array}{r} 8 \\ \times 5 \\ \hline 40 \end{array}$$

14.
$$\begin{array}{r} 9 \\ \times 9 \\ \hline 81 \end{array}$$

15.
$$\begin{array}{r} 8 \\ \times 9 \\ \hline 72 \end{array}$$

16.
$$\begin{array}{r} 7 \\ \times 7 \\ \hline 49 \end{array}$$

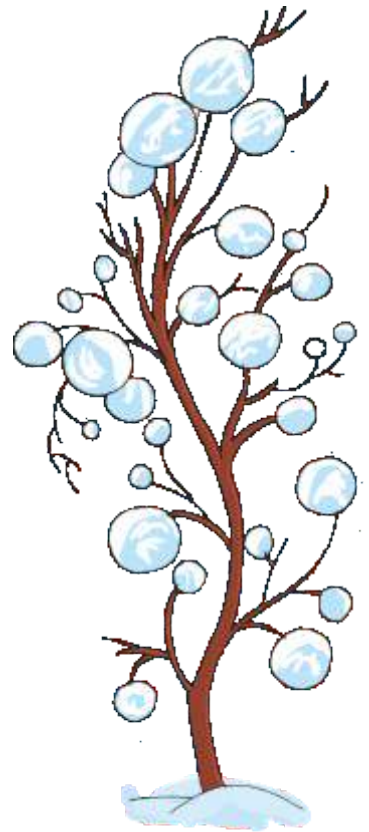

Quick Response 4.3

1. Fill in the blanks.

a) $5 \times 1 = \boxed{5}$

b) $7 \times 0 = \boxed{0}$

c) $9 \times 1 = \boxed{9}$

d) $12 \times 0 = \boxed{0}$

e) $15 \times 1 = \boxed{15}$

f) $19 \times 1 = \boxed{19}$

2. Find the product.

a)
$$\begin{array}{r} 8 \\ \times 1 \\ \hline 8 \end{array}$$

b)
$$\begin{array}{r} 9 \\ \times 0 \\ \hline 0 \end{array}$$

c)
$$\begin{array}{r} 18 \\ \times 0 \\ \hline 0 \end{array}$$

d)
$$\begin{array}{r} 15 \\ \times 1 \\ \hline 15 \end{array}$$



3. Fill in the missing numbers.

a) $7 \times 8 = 8 \times \underline{7}$

b) $9 \times \underline{1} = 9$

c) $12 \times 4 = \underline{4} \times 12$

d) $9 \times \underline{0} = 0$

e) $8 \times 5 = 5 \times \underline{8}$

f) $15 \times \underline{0} = 0$



 **Quick Response 44**

1. Write the multiplication statements for the following jumps on the number lines. One has been done.

b) Multiply 5 by 4.

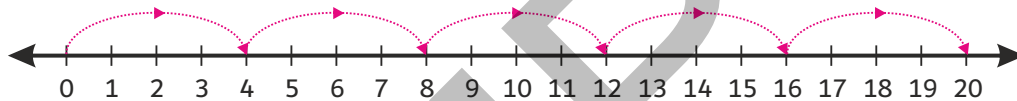

$5 \times 4 = 20$

c) Multiply 6 by 3.

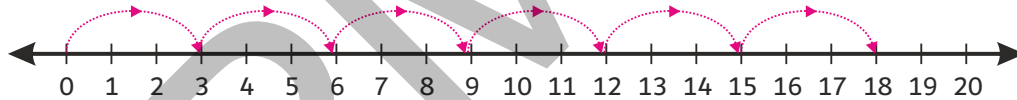

$6 \times 3 = 18$

2. Multiply the following on the number lines.

a) $3 \times 5 = \underline{15}$

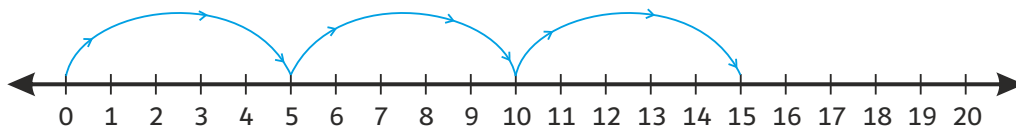

b) $7 \times 2 =$ 14

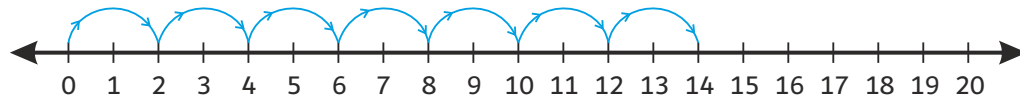

c) $8 \times 2 =$ 16

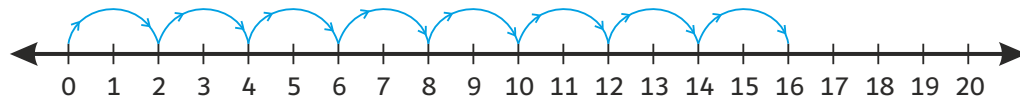

d) $5 \times 4 =$ 20

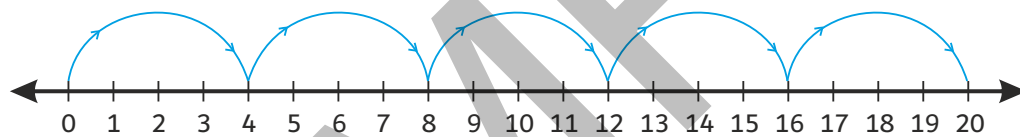

e) $5 \times 3 =$ 15

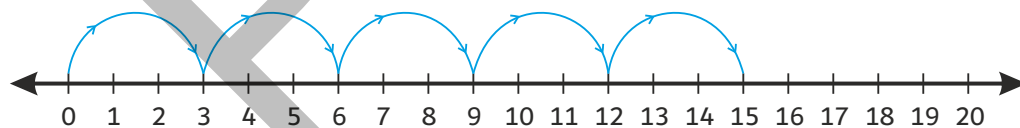

f) $4 \times 4 =$ 16

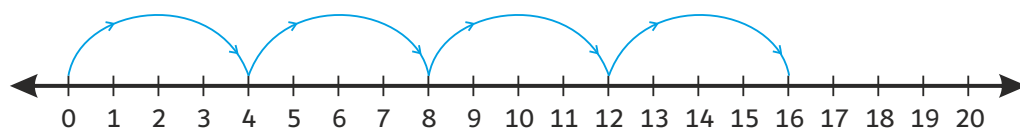



Quick Response 4.5

Multiply and find the product.

1.

T	O
1	2
×	2
2	4

2.

T	O
1	3
×	3
3	9

3.

T	O
2	2
×	3
6	6

4.

T	O
2	1
×	4
8	4

5.

T	O
2	3
×	2
4	6

6.

T	O
3	2
×	2
6	4

7.

T	O
4	1
×	2
8	2

8.

T	O
2	2
×	4
8	8

9.

T	O
1	2
×	4
4	8

10.

T	O
3	1
×	3
9	3

11.

T	O
3	3
×	3
9	9

12.

T	O
3	2
×	3
9	6

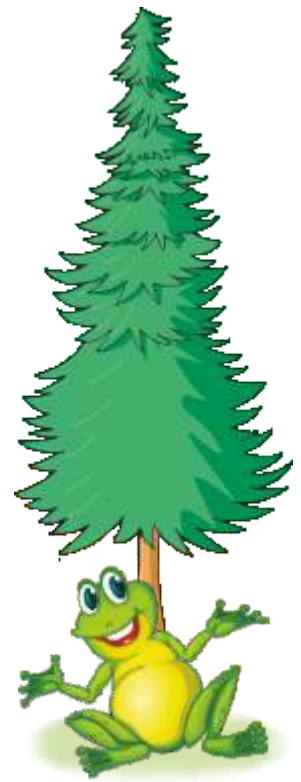

Quick Response 4.6

Multiply and find the product.

1.

H	T	O
	3	4
	×	3
1	0	2

2.

H	T	O
	5	4
	×	2
1	0	8

3.

H	T	O
	2	8
	×	4
1	1	2

4.

H	T	O
	6	9
	×	2
1	3	8

5.

H	T	O
	4	8
	×	4
1	9	2

6.

H	T	O
	3	9
	×	5
1	9	5

7.

H	T	O
	3	4
	×	5
1	7	0

8.

H	T	O
	2	7
	×	7
1	8	9





Quick Response 4.7

Solve the following word problems.

1. There were 15 cars. Each car had 4 passengers. How many passengers were there in all?

Number of cars
Passengers in each car
Total number of passengers

H	T	O
	1	5
	×	4
	6	0



2. There were 56 children. Each child ate 2 bananas. How many bananas were eaten in all?

Total number of children
Bananas eaten by each child
Total number of bananas eaten

H	T	O
	5	6
	×	2
1	1	2



3. There are 36 apples on a tree. How many apples are there on 5 trees?

Number of apples on 1 tree
Total number of trees
Total number of apples

H	T	O
	3	6
	×	5
1	8	0



4. If one boy has 24 toffees, how many toffees do 6 boys have?

Number of toffees each boy has
Number of boys
Total number of toffees

H	T	O
	2	4
	×	6
1	4	4



5. A jeep has 4 wheels. How many wheels are there in 32 jeeps?

Total number of jeeps
Wheels in each jeep
Total number of wheels

H	T	O
	3	2
	×	4
1	2	8



6. A jug can hold 5 glasses of water. How many glasses of water can 22 such jugs hold?

Total number of jugs
Number of glasses of water that each jug can hold
Total number of glasses of water that all jugs can hold

H	T	O
	2	2
	×	5
1	1	0

7. There are 36 children. Each child has 4 notebooks. How many notebooks do they have altogether?

Total number of children
Number of notebooks each child has
Total number of notebooks

H	T	O
	3	6
	×	4
1	4	4

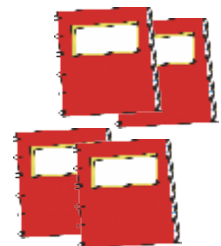

Chapter Review

1. Fill in the blanks.

a) $5 \times 4 = \underline{\quad 20 \quad}$

b) $7 \times 8 = \underline{\quad 56 \quad}$

c) $7 \times 6 = \underline{\quad 42 \quad}$

d) $\underline{\quad 0 \quad} \times 8 = 0$

e) $15 \times 0 = \underline{\quad 0 \quad}$

f) $\underline{\quad 8 \quad} \times 9 = 72$

g) $27 \times 1 = \underline{\quad 27 \quad}$

h) $6 \times \underline{\quad 7 \quad} = 7 \times 6$



2. Multiply the following.

a)

2	3
×	2
4	6

b)

2	1
×	4
8	4

c)

3	2
×	3
9	6

3. Multiply these, too.

a)

	3	7
	×	4
1	4	8

b)

	4	5
	×	5
2	2	5

c)

	2	6
	×	5
1	3	0

4. There are 6 ice-cubes in an ice-tray. How many ice-cubes will be there in 9 such ice-trays?

There will be ice-cubes.

Critical Thinking

The price of a chocobar is ₹ 20 and a cone ice-cream is ₹ 35. How much money will I need to buy 3 chocobars and 4 cone ice-creams?

$$3 \times ₹20 + 4 \times ₹35 = 60 + 140 = ₹200$$

Social-emotional Learning

Alia's class has decided to go for a picnic. The teacher has asked each child to give ₹100. But there is a poor child who cannot pay for it. If 20 children give ₹ 5 each, how much money will be collected for the poor child?

₹100

What value do you learn from this act of these 20 children?

Helpfulness



■■■ Cross Curricular

Ms Manpreet, Mr Akram and Mr Jaspreet go to their offices by car. Each one consumes 5 litres of petrol every day. How many litres of petrol are consumed by all the three every day? If they use car pool, how much petrol can they save every day?

Ans. Petrol consumed by all three every day = $5 \times 3 = 15$ litres

It they use car pool, they can save 10 litres petrol every day.



■■■ Communication Skill

Shefali gives food and water to her pet dog on time. If her pet dog eats 8 slices of bread every day, how many slices of bread does it eat in a week?

$8 \times 7 = 56$ slices

If you have a pet, tell the class how you take care of it.

Answer it yourself



5

Division



Get Ready

Count and write the number of groups you have made.

Do it yourself.



Quick Response 5.1

Make equal groups of objects and divide.

1. Divide 9 balloons among 3 children.



$$9 \div 3 = \boxed{3}$$

2. Divide 8 balls among 2 children.



$$8 \div 2 = \boxed{4}$$

3. Divide 12 teddy bears among 4 children.



$$12 \div 4 = \boxed{3}$$



4. Divide 16 marbles among 2 children.

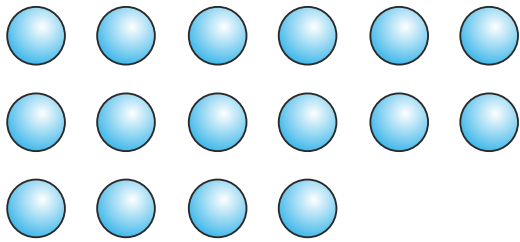

$$16 \div 2 = 8$$



Show each division statement on the number line.

1. $15 \div 5 = 3$

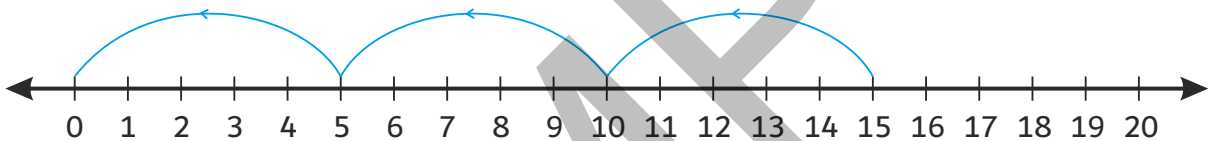

How many jumps?

3

So, $15 \div 5 =$

3

2. $16 \div 2 = 8$

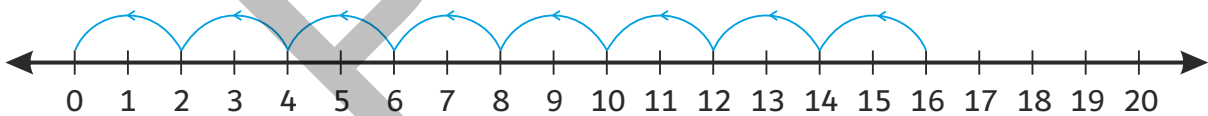

How many jumps?

8

So, $16 \div 2 =$

8

3. $18 \div 6 = 3$

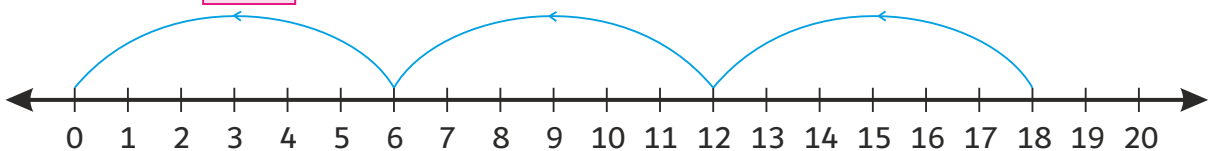

How many jumps?

3

So, $18 \div 6 =$

3





Quick Response 5.3

Write the two division facts for each multiplication fact given below.

1. $6 \times 4 = 24$
 $24 \div 4 = 6, 24 \div 6 = 4$

2. $5 \times 3 = 15$
 $15 \div 3 = 5, 15 \div 5 = 3$

3. $4 \times 5 = 20$
 $20 \div 5 = 4, 20 \div 4 = 5$



Quick Response 5.4

1. Divide and write the quotient.

a) $4 \div 4 = \boxed{1}$ b) $0 \div 7 = \boxed{0}$ c) $12 \div 12 = \boxed{1}$
d) $5 \div 1 = \boxed{5}$ e) $7 \div 7 = \boxed{1}$ f) $15 \div 1 = \boxed{15}$
g) $6 \div 6 = \boxed{1}$ h) $0 \div 1 = \boxed{0}$ i) $15 \div 15 = \boxed{1}$

2. Fill in the blanks.

a) $9 \div 1 = \underline{\quad 9 \quad}$ b) $12 \div 1 = \underline{\quad 12 \quad}$
c) $\underline{\quad 0 \quad} \div 7 = 0$ d) $8 \div \underline{\quad 1 \quad} = 8$
e) $9 \div \underline{\quad 9 \quad} = 1$ f) $\underline{\quad 0 \quad} \div 9 = 0$
g) $10 \div 1 = \underline{\quad 10 \quad}$ h) $15 \div 15 = \underline{\quad 1 \quad}$





Quick Response 5.5

1. Divide and write the quotient in the box. One has been done for you.

a)
$$\begin{array}{r} 5 \\ 2 \overline{) 10} \\ -10 \\ \hline 0 \end{array}$$

b)
$$\begin{array}{r} 3 \\ 3 \overline{) 9} \\ -9 \\ \hline 0 \end{array}$$

c)
$$\begin{array}{r} 4 \\ 3 \overline{) 12} \\ -12 \\ \hline 0 \end{array}$$

d)
$$\begin{array}{r} 9 \\ 2 \overline{) 18} \\ -18 \\ \hline 0 \end{array}$$

e)
$$\begin{array}{r} 3 \\ 4 \overline{) 12} \\ -12 \\ \hline 0 \end{array}$$

f)
$$\begin{array}{r} 5 \\ 5 \overline{) 25} \\ -25 \\ \hline 0 \end{array}$$

g)
$$\begin{array}{r} 9 \\ 5 \overline{) 45} \\ -45 \\ \hline 0 \end{array}$$

h)
$$\begin{array}{r} 4 \\ 6 \overline{) 24} \\ -24 \\ \hline 0 \end{array}$$

i)
$$\begin{array}{r} 8 \\ 6 \overline{) 48} \\ -48 \\ \hline 0 \end{array}$$

j)
$$\begin{array}{r} 7 \\ 7 \overline{) 49} \\ -49 \\ \hline 0 \end{array}$$

k)
$$\begin{array}{r} 9 \\ 7 \overline{) 63} \\ -63 \\ \hline 0 \end{array}$$

l)
$$\begin{array}{r} 8 \\ 8 \overline{) 64} \\ -64 \\ \hline 0 \end{array}$$

2. Solve the division sentences and also solve them by long division method. One has been done for you.

a) $24 \div 4 =$
$$\begin{array}{r} 6 \\ 4 \overline{) 24} \\ -24 \\ \hline 0 \end{array}$$

b) $27 \div 3 =$
$$\begin{array}{r} 9 \\ 3 \overline{) 27} \\ -27 \\ \hline 0 \end{array}$$

c) $42 \div 6 =$
$$\begin{array}{r} 7 \\ 6 \overline{) 42} \\ -42 \\ \hline 0 \end{array}$$

d) $56 \div 7 =$
$$\begin{array}{r} 8 \\ 7 \overline{) 56} \\ -56 \\ \hline 0 \end{array}$$

e) $40 \div 8 =$
$$\begin{array}{r} 5 \\ 8 \overline{) 40} \\ -40 \\ \hline 0 \end{array}$$

f) $63 \div 9 =$
$$\begin{array}{r} 7 \\ 9 \overline{) 63} \\ -63 \\ \hline 0 \end{array}$$





Quick Response 5.6

Solve the following.

1. 15 marbles are to be distributed among 5 children. How many marbles will each child get?

Each child will get marbles.

$$\begin{array}{r} 3 \\ 5 \overline{) 15} \\ \underline{-15} \\ 0 \end{array}$$

2. 36 people are to be sent by cars. If 4 people can sit in a car, how many cars will be required?

cars will be required.

$$\begin{array}{r} 9 \\ 4 \overline{) 36} \\ \underline{-36} \\ 0 \end{array}$$

3. 35 mangoes are to be shared equally among 7 friends. How many mangoes will each friend get?

Each friend will get mangoes.

$$\begin{array}{r} 5 \\ 7 \overline{) 35} \\ \underline{-35} \\ 0 \end{array}$$

4. 54 flowers are to be kept equally in 6 vases. How many flowers should be kept in each vase?

flowers will be kept in each vase.

$$\begin{array}{r} 9 \\ 6 \overline{) 54} \\ \underline{-54} \\ 0 \end{array}$$

5. 48 sweets are to be shared among 8 children. How many sweets will each child get?

Each child will get sweets.

$$\begin{array}{r} 6 \\ 8 \overline{) 48} \\ \underline{-48} \\ 0 \end{array}$$





Chapter Review

1. Divide the following on the number line.

a) $15 \div 3 = \boxed{5}$

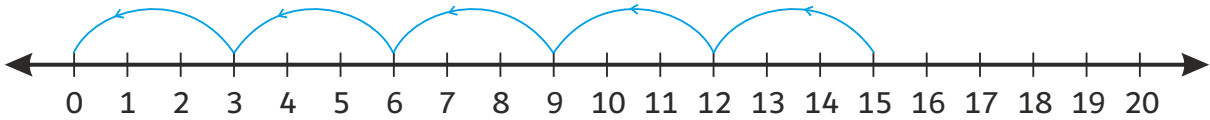

b) $18 \div 6 = \boxed{3}$

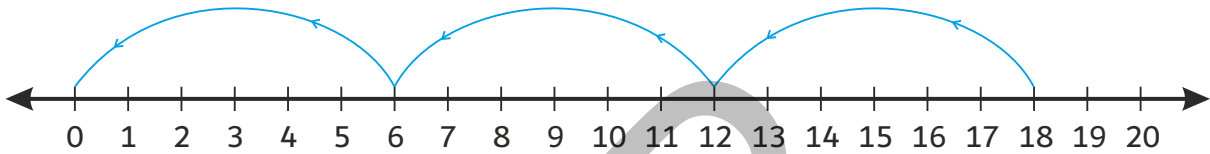

2. Divide the following.

a) $16 \div 4 = \boxed{4}$

b) $25 \div 5 = \boxed{5}$

c) $24 \div 6 = \boxed{4}$

d) $72 \div 8 = \boxed{9}$

e) $16 \div 2 = \boxed{8}$

f) $42 \div 7 = \boxed{6}$

3. Fill in the blanks.

a) $12 \div 1 = \underline{\quad 12 \quad}$

b) $7 \div \underline{\quad 7 \quad} = 1$

c) $0 \div 9 = \underline{\quad 0 \quad}$

d) $8 \div 8 = \underline{\quad 1 \quad}$

4. Divide the following.

a)
$$\begin{array}{r} 8 \\ 6 \overline{) 48} \\ \underline{-48} \\ 0 \end{array}$$

b)
$$\begin{array}{r} 8 \\ 7 \overline{) 56} \\ \underline{-56} \\ 0 \end{array}$$

c)
$$\begin{array}{r} 9 \\ 9 \overline{) 81} \\ \underline{-81} \\ 0 \end{array}$$

d)
$$\begin{array}{r} 8 \\ 8 \overline{) 64} \\ \underline{-64} \\ 0 \end{array}$$



5. 21 gulab jamuns are to be shared equally among 7 children. How many gulab jamuns will each child get?

Each child will get gulab jamuns.

Critical Thinking

When Raghav peeped into a stable, he saw only the legs of horses and men. If he counted 24 legs of horses and 8 legs of men, how many horses and men were there in the stable?

Ans. Horses = $24 \div 4 = 6$ Men $8 \div 2 = 4$

Social-emotional Learning

You live in a joint family. You have 1 sibling and 4 cousins. You get 24 chocolates from one of your relatives. Will you share the chocolates with your sibling and cousins?

Answer it yourself



6

Numbers up to 1000



Get Ready

1. Write the following in numerals.

a) One hundred forty-two 142

b) One hundred ninety-eight 198

2. Write the following numbers in words.

a) 107 : One hundred seven

b) 184 : One hundred eighty four



3. Write the place value and face value of the circled digits.

a) 1 4 5 Place value 40 Face value 4

b) 2 0 0 Place value 200 Face value 2

4. Circle the largest number.

a) 105 59 150 b) 176 165 179

5. Write the following in ascending order.

a) 117, 95, 107, 54 54, 95, 107, 117

b) 167, 145, 169, 170 145, 167, 169, 170

6. Write the following in descending order.

a) 101, 99, 107, 96 107, 101, 99, 96

b) 174, 170, 169, 164 174, 170, 169, 164





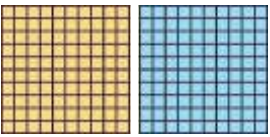
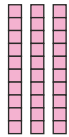
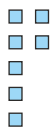

Quick Response 6.1

1. Write the number of hundreds, tens and ones in the following.

a)   

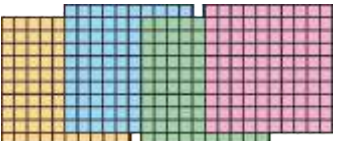
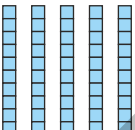

H	T	O
2	3	7

hundreds tens ones

b)   

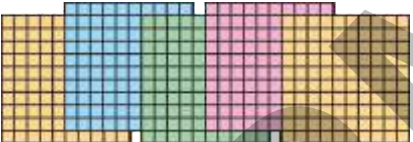
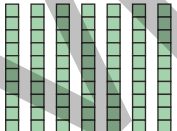

H	T	O
4	5	2

hundreds tens ones

c)   

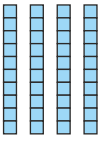

H	T	O
5	7	9

hundreds tens ones

d)   

H	T	O
8	4	4

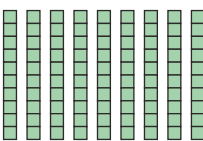
hundreds tens ones

e)   

H	T	O
9	9	9

hundreds tens ones

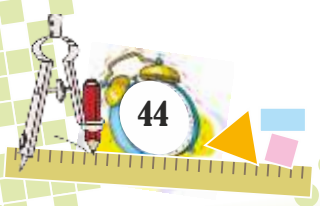

2. Complete the number grids by filling the missing numbers.

a)

201	202	203	204	205	206	207	208	209	210
211	212	213	214	215	216	217	218	219	220
221	222	223	224	225	226	227	228	229	230
231	232	233	234	235	236	237	238	239	240
241	242	243	244	245	246	247	248	249	250
251	252	253	254	255	256	257	258	259	260
261	262	263	264	265	266	267	268	269	270
271	272	273	274	275	276	277	278	279	280
281	282	283	284	285	286	287	288	289	290
291	292	293	294	295	296	297	298	299	300

b)

301	302	303	304	305	306	307	308	309	310
311	312	313	314	315	316	317	318	319	320
321	322	323	324	325	326	327	228	329	330
331	332	333	334	335	336	337	338	339	340
341	342	343	344	345	346	347	348	349	350
351	352	353	354	355	356	357	358	359	360
361	362	363	364	365	366	367	368	369	370
371	372	373	374	375	376	377	378	379	380
381	382	383	384	385	386	387	388	389	390
391	392	393	394	395	396	397	398	399	400



c)

401	402	403	404	405	406	407	408	409	410
411	412	413	414	415	416	417	418	419	420
421	422	423	424	425	426	427	428	429	430
431	432	433	434	435	436	437	438	439	440
441	442	443	444	445	446	447	448	449	450
451	452	453	454	455	456	457	458	459	460
461	462	463	464	465	466	467	468	469	470
471	472	473	474	475	476	477	478	479	480
481	482	483	484	485	486	487	488	489	490
491	492	493	494	495	496	497	498	499	500

d)

501	502	503	504	505	506	507	508	509	510
511	512	513	514	515	516	517	518	519	520
521	522	523	524	525	526	527	528	529	530
531	532	533	534	535	536	537	538	539	540
541	542	543	544	545	546	547	548	549	550
551	552	553	554	555	556	557	558	559	560
561	562	563	564	565	566	567	568	569	570
571	572	573	574	575	576	577	578	579	580
581	582	583	584	585	586	587	588	589	590
591	592	593	594	595	596	597	598	599	600



e)

601	602	603	604	605	606	607	608	609	610
611	612	613	614	615	616	617	618	619	620
621	622	623	624	625	626	627	628	629	630
631	632	633	634	635	636	637	638	639	640
641	642	643	644	645	646	647	648	649	650
651	652	653	654	655	656	657	658	659	660
661	662	663	664	665	666	667	668	669	670
671	672	673	674	675	676	677	678	679	680
681	682	683	684	685	686	687	688	689	690
691	692	693	694	695	696	697	698	699	700

f)

701	702	703	704	705	706	707	708	709	710
711	712	713	714	715	716	717	718	719	720
721	722	723	724	725	726	727	728	729	730
731	732	733	734	735	736	737	738	739	740
741	742	743	744	745	746	747	748	749	750
751	752	753	754	755	756	757	758	759	760
761	762	763	764	765	766	767	768	769	770
771	772	773	774	775	776	777	778	779	780
781	782	783	784	785	786	787	788	789	790
791	792	793	794	795	796	797	798	799	800



g)

801	802	803	804	805	806	807	808	809	810
811	812	813	814	815	816	817	818	819	820
821	822	823	824	825	826	827	828	829	830
831	832	833	834	835	836	837	838	839	840
841	842	843	844	845	846	847	848	849	850
851	852	853	854	855	856	857	858	859	860
861	862	863	864	865	866	867	868	869	870
871	872	873	874	875	876	877	878	879	880
881	882	883	884	885	886	887	888	889	890
891	892	893	894	895	896	897	898	899	900

h)

901	902	903	904	905	906	907	908	909	910
911	912	913	914	915	916	917	918	919	920
921	922	923	924	925	926	927	928	929	930
931	932	933	934	935	936	937	938	939	940
941	942	943	944	945	946	947	948	949	950
951	952	953	954	955	956	957	958	959	960
961	962	963	964	965	966	967	968	969	970
971	972	973	974	975	976	977	978	979	980
981	982	983	984	985	986	987	988	989	990
991	992	993	994	995	996	997	998	999	1000





Quick Response 6.2

1. Write the following in words.

- a) 237 : Two hundred thirty seven
- b) 405 : Four hundred five
- c) 720 : Seven hundred twenty
- d) 875 : Eight hundred seventy five
- e) 964 : Nine hundred sixty four

2. Write the following in numerals.

- a) Two hundred nineteen 219
- b) Five hundred nine 509
- c) Seven hundred 700
- d) Eight hundred eighty-eight 888
- e) Nine hundred fifty-seven 957



Quick Response 6.3

1. Write the predecessor of the following numbers.

- a) 236 237
- b) 355 356
- c) 639 640
- d) 796 797
- e) 849 850
- f) 999 1000

2. Write the successor of the following numbers.

- a) 249 250
- b) 300 301
- c) 547 548
- d) 625 626
- e) 879 880
- f) 919 920



3. Write the number that comes between the two numbers in each of the following.

- | | | | | | |
|--------|----------------------------------|-----|--------|----------------------------------|-----|
| a) 260 | <input type="text" value="261"/> | 262 | b) 419 | <input type="text" value="420"/> | 421 |
| c) 555 | <input type="text" value="556"/> | 557 | d) 738 | <input type="text" value="739"/> | 740 |
| e) 848 | <input type="text" value="849"/> | 850 | f) 939 | <input type="text" value="940"/> | 941 |

 **Quick Response 6.4**

1. Write the place value of the circled digits.

- | | | | |
|----------|-----------|----------|------------|
| a) 2(4)6 | <u>40</u> | b) (6)71 | <u>600</u> |
| c) 75(9) | <u>9</u> | d) 9(0)5 | <u>0</u> |

2. Write the face value of the circled digits.

- | | | | |
|----------|----------|----------|----------|
| a) 3(7)8 | <u>7</u> | b) (5)23 | <u>5</u> |
| c) 65(0) | <u>0</u> | d) (8)56 | <u>8</u> |

3. Write the following numbers in expanded form.

- | | |
|------------------------------|------------------------------|
| a) 214 = <u>200 + 10 + 4</u> | b) 405 = <u>400 + 5</u> |
| c) 720 = <u>700 + 20</u> | d) 995 = <u>900 + 90 + 5</u> |

4. Write the following numbers in short form.

- | | |
|------------------------------|------------------------------|
| a) 300 + 50 = <u>350</u> | b) 500 + 5 = <u>505</u> |
| c) 700 + 30 + 6 = <u>736</u> | d) 900 + 10 + 1 = <u>911</u> |

 **Quick Response 6.5**

1. Put < or > sign in the boxes.

- | | |
|--|--|
| a) 324 <input type="text" value=">"/> 98 | b) 527 <input type="text" value="<"/> 537 |
| c) 741 <input type="text" value="<"/> 745 | d) 105 <input type="text" value="<"/> 404 |
| e) 649 <input type="text" value=">"/> 639 | f) 910 <input type="text" value="<"/> 915 |

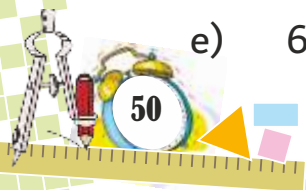

2. Circle the largest number and cross the smallest number.

- a) ~~245~~ 314 536 b) 806 ~~739~~ 789
c) ~~401~~ 425 421 d) 936 948 ~~919~~
e) 700 649 ~~450~~ f) 647 645 ~~642~~

3. Write the following in ascending order.

- a) 307, 409, 907, 804 307, 409, 804, 907
b) 647, 689, 576, 567 567, 576, 647, 689

4. Write the following in descending order.

- a) 478, 375, 485, 588 588, 485, 478, 375
b) 826, 929, 919, 845 929, 919, 845, 826



Quick Response 6.6



Form the largest and the smallest numbers from the given digits.

	Largest	Smallest
1. 6, 4 and 7	<u>764</u>	<u>467</u>
2. 9, 0 and 8	<u>980</u>	<u>809</u>
3. 5, 3 and 6	<u>653</u>	<u>356</u>





Chapter Review

1. Tick (✓) the correct option.

- a) Five hundred sixty-nine is written as _____.
- i) 576 ii) 569 iii) 596
- b) Which of the following is largest?
- i) 776 ii) 767 iii) 766
- c) Which of the following is smallest?
- i) 809 ii) 890 iii) 799
- d) The place value of 3 in 739 is _____.
- i) 300 ii) 30 iii) 3

2. Write the following in figures.

- a) Seven hundred forty-nine 749
- b) Nine hundred eighty-five 985

3. Write the following in words.

- a) 509 : Five hundred nine
- b) 996 : Nine hundred ninety six

4. Write the successor and predecessor of the following.

- a) 689 690 691 b) 699 700 701

5. Write the following in expanded form.

- a) 710 : 700 + 10
- b) 889 : 800 + 80 + 9



Which number will be the largest if we replace the digits at the ones place with the digits at the hundreds place in each of the following numbers?

734

596

895

596

Ria, Tina and Anu used 432 litres, 396 litres and 516 litres of water respectively. Who used the largest amount of water? Anu

What should we do to save water? Answer it yourself

Model Test Paper - I

(Based on Chapters 1 to 6)

1. Tick (✓) the correct option.

a) What is the place value of 3 in 235?

i) 3 ii) 30 iii) 300

b) Which of the following is an odd number?

i) 12 ii) 15 iii) 18

c) Which of the following is largest?

i) 207 ii) 701 iii) 719

d) $98 - 98 = ?$

i) 0 ii) 1 iii) 98

e) $7 \times 5 = ?$

i) 25 ii) 30 iii) 35

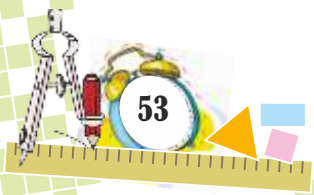

2. Write the following numbers in words.

- a) 179 : One hundred seventy nine
 b) 649 : Six hundred forty nine

3. Write the following numbers in numerals.

- a) Four hundred forty-four : 444
 b) Nine hundred nine : 909

4. Add the following. Regroup if required.

- a)

	4	2
+	2	3
	6	5

 b)

	7	7
+	8	4
1	6	1

 c)

	4	7
+	8	6
1	3	3

 d)

	2	9
+	7	5
1	0	4

5. Subtract the following. Regroup if required.

- a)

	7	8
-	5	4
	2	4

 b)

	9	6
-	8	4
1		2

 c)

	7	2
-	4	7
2		5

 d)

	8	0
-	5	5
	2	5

6. Solve the following.

- a) There were 48 birds on a tree. 36 more birds came to the tree. How many birds were there on the tree altogether?

4	8	
+	3	6
8	4	
- b) A shopkeeper had 82 chocolates. He sold 36 chocolates. How many chocolates are left with him now?

8	2	
-	3	6
4	6	

7. Arrange the following in ascending order.

- a) 274, 402, 139, 824 139, 274, 402, 824
 b) 864, 876, 904, 914 864, 876, 904, 914

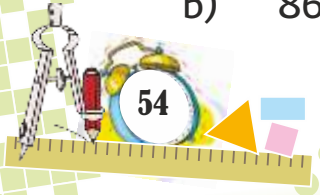

8. Multiply the following.

a)
$$\begin{array}{r} 7 \\ \times 4 \\ \hline 28 \end{array}$$

b)
$$\begin{array}{r} 8 \\ \times 9 \\ \hline 72 \end{array}$$

c)
$$\begin{array}{r} 12 \\ \times 3 \\ \hline 36 \end{array}$$

d)
$$\begin{array}{r} 32 \\ \times 4 \\ \hline 128 \end{array}$$

9. Divide the following.

a)
$$\begin{array}{r} 4 \\ 4 \overline{) 16} \\ \underline{-16} \\ 0 \end{array}$$

b)
$$\begin{array}{r} 4 \\ 5 \overline{) 20} \\ \underline{-20} \\ 0 \end{array}$$

c)
$$\begin{array}{r} 6 \\ 6 \overline{) 36} \\ \underline{-36} \\ 0 \end{array}$$

d)
$$\begin{array}{r} 7 \\ 9 \overline{) 63} \\ \underline{-63} \\ 0 \end{array}$$

PMP



7

Addition and Subtraction



Get Ready

1. Add the following by forward counting.

a) $15 + 4 = \underline{19}$ b) $21 + 7 = \underline{28}$ c) $34 + 6 = \underline{40}$

2. Subtract the following by backward counting.

a) $28 - 6 = \underline{22}$ b) $54 - 5 = \underline{49}$ c) $88 - 7 = \underline{81}$

3. Add the following. Regroup if required.

a)

T	O	
4	2	
+	2	6
6	8	

b)

T	O	
6	0	
+	3	7
9	7	

c)

T	O	
3	7	
+	2	9
6	6	

d)

T	O	
5	4	
+	3	9
9	3	

4. Subtract the following. Regroup if required.

a)

T	O	
4	2	
-	2	6
1	6	

b)

T	O	
6	7	
-	4	0
2	7	

c)

T	O	
5	2	
-	3	4
1	8	

d)

T	O	
8	0	
-	4	5
3	5	

5. Drishti got 34 marks in Test-1 and 48 marks in Test-2. Find her total marks. $\underline{34 + 48 = 82}$

6. Jayant got 68 marks and his friend got 89 marks. How many less marks did he get than his friend? $\underline{89 - 68 = 21}$





Quick Response 7.1

Add the following.

$$\begin{array}{r} \text{H} \quad \text{T} \quad \text{O} \\ 2 \quad 4 \quad 6 \\ + \quad 3 \quad 2 \\ \hline 2 \quad 7 \quad 8 \end{array}$$

$$\begin{array}{r} \text{H} \quad \text{T} \quad \text{O} \\ 5 \quad 1 \quad 2 \\ + \quad 7 \quad 6 \\ \hline 5 \quad 8 \quad 8 \end{array}$$

$$\begin{array}{r} \text{H} \quad \text{T} \quad \text{O} \\ \quad \quad 4 \quad 2 \\ + \quad 4 \quad 4 \quad 3 \\ \hline 4 \quad 8 \quad 5 \end{array}$$

$$\begin{array}{r} \text{H} \quad \text{T} \quad \text{O} \\ 8 \quad 2 \quad 5 \\ + \quad 2 \quad 0 \\ \hline 8 \quad 4 \quad 5 \end{array}$$

$$\begin{array}{r} \text{H} \quad \text{T} \quad \text{O} \\ 6 \quad 0 \quad 7 \\ + \quad 9 \quad 2 \\ \hline 6 \quad 9 \quad 9 \end{array}$$

$$\begin{array}{r} \text{H} \quad \text{T} \quad \text{O} \\ 7 \quad 5 \quad 3 \\ + \quad 2 \quad 6 \\ \hline 7 \quad 7 \quad 9 \end{array}$$

$$\begin{array}{r} \text{H} \quad \text{T} \quad \text{O} \\ 5 \quad 5 \quad 2 \\ + \quad 3 \quad 4 \\ \hline 5 \quad 8 \quad 6 \end{array}$$

$$\begin{array}{r} \text{H} \quad \text{T} \quad \text{O} \\ \quad \quad 1 \quad 2 \\ + \quad 6 \quad 7 \quad 7 \\ \hline 6 \quad 8 \quad 9 \end{array}$$



Quick Response 7.2

Add the following.

$$\begin{array}{r} \text{H} \quad \text{T} \quad \text{O} \\ 2 \quad 0 \quad 4 \\ + \quad 3 \quad 2 \quad 4 \\ \hline 5 \quad 2 \quad 8 \end{array}$$

$$\begin{array}{r} \text{H} \quad \text{T} \quad \text{O} \\ 5 \quad 1 \quad 6 \\ + \quad 3 \quad 4 \quad 2 \\ \hline 8 \quad 5 \quad 8 \end{array}$$

$$\begin{array}{r} \text{H} \quad \text{T} \quad \text{O} \\ 6 \quad 1 \quad 0 \\ + \quad 2 \quad 4 \quad 7 \\ \hline 8 \quad 5 \quad 7 \end{array}$$

$$\begin{array}{r} \text{H} \quad \text{T} \quad \text{O} \\ 4 \quad 2 \quad 4 \\ + \quad 3 \quad 2 \quad 4 \\ \hline 7 \quad 4 \quad 8 \end{array}$$

$$\begin{array}{r} \text{H} \quad \text{T} \quad \text{O} \\ 1 \quad 2 \quad 1 \\ + \quad 7 \quad 6 \quad 7 \\ \hline 8 \quad 8 \quad 8 \end{array}$$

$$\begin{array}{r} \text{H} \quad \text{T} \quad \text{O} \\ 3 \quad 0 \quad 2 \\ + \quad 4 \quad 8 \quad 6 \\ \hline 7 \quad 8 \quad 8 \end{array}$$

$$\begin{array}{r} \text{H} \quad \text{T} \quad \text{O} \\ 8 \quad 2 \quad 5 \\ + \quad 1 \quad 7 \quad 4 \\ \hline 9 \quad 9 \quad 9 \end{array}$$

$$\begin{array}{r} \text{H} \quad \text{T} \quad \text{O} \\ 6 \quad 3 \quad 0 \\ + \quad 2 \quad 4 \quad 7 \\ \hline 8 \quad 7 \quad 7 \end{array}$$



Quick Response 7.3

Add the following.

$$\begin{array}{r} \text{H} \quad \text{T} \quad \text{O} \\ 2 \quad 4 \quad 7 \\ + \quad 1 \quad 6 \quad 5 \\ \hline 4 \quad 1 \quad 2 \end{array}$$

$$\begin{array}{r} \text{H} \quad \text{T} \quad \text{O} \\ 3 \quad 7 \quad 9 \\ + \quad 2 \quad 4 \quad 6 \\ \hline 6 \quad 2 \quad 5 \end{array}$$

$$\begin{array}{r} \text{H} \quad \text{T} \quad \text{O} \\ 3 \quad 7 \quad 6 \\ + \quad 4 \quad 8 \quad 5 \\ \hline 8 \quad 6 \quad 1 \end{array}$$

$$\begin{array}{r} \text{H} \quad \text{T} \quad \text{O} \\ 5 \quad 2 \quad 7 \\ + \quad 2 \quad 9 \quad 4 \\ \hline 8 \quad 2 \quad 1 \end{array}$$



$$\begin{array}{r} 5. \quad \text{H} \quad \text{T} \quad \text{O} \\ \quad 3 \quad 5 \quad 7 \\ + \quad 1 \quad 9 \quad 5 \\ \hline \quad 5 \quad 5 \quad 2 \end{array}$$

$$\begin{array}{r} 6. \quad \text{H} \quad \text{T} \quad \text{O} \\ \quad 4 \quad 2 \quad 7 \\ + \quad 3 \quad 4 \quad 6 \\ \hline \quad 7 \quad 7 \quad 3 \end{array}$$

$$\begin{array}{r} 7. \quad \text{H} \quad \text{T} \quad \text{O} \\ \quad 5 \quad 1 \quad 9 \\ + \quad 1 \quad 7 \quad 6 \\ \hline \quad 6 \quad 9 \quad 5 \end{array}$$

$$\begin{array}{r} 8. \quad \text{H} \quad \text{T} \quad \text{O} \\ \quad 5 \quad 0 \quad 5 \\ + \quad 2 \quad 9 \quad 6 \\ \hline \quad 8 \quad 0 \quad 1 \end{array}$$

$$\begin{array}{r} 9. \quad \text{H} \quad \text{T} \quad \text{O} \\ \quad 4 \quad 5 \quad 8 \\ + \quad 2 \quad 7 \quad 5 \\ \hline \quad 7 \quad 3 \quad 3 \end{array}$$

$$\begin{array}{r} 10. \quad \text{H} \quad \text{T} \quad \text{O} \\ \quad 3 \quad 0 \quad 5 \\ + \quad 4 \quad 9 \quad 8 \\ \hline \quad 8 \quad 0 \quad 3 \end{array}$$

$$\begin{array}{r} 11. \quad \text{H} \quad \text{T} \quad \text{O} \\ \quad 2 \quad 0 \quad 7 \\ + \quad 2 \quad 9 \quad 8 \\ \hline \quad 5 \quad 0 \quad 5 \end{array}$$

$$\begin{array}{r} 12. \quad \text{H} \quad \text{T} \quad \text{O} \\ \quad 5 \quad 2 \quad 5 \\ + \quad 2 \quad 7 \quad 9 \\ \hline \quad 8 \quad 0 \quad 4 \end{array}$$

$$\begin{array}{r} 13. \quad \text{H} \quad \text{T} \quad \text{O} \\ \quad 1 \quad 7 \quad 8 \\ + \quad 2 \quad 7 \quad 5 \\ \hline \quad 4 \quad 5 \quad 3 \end{array}$$

$$\begin{array}{r} 14. \quad \text{H} \quad \text{T} \quad \text{O} \\ \quad 3 \quad 5 \quad 5 \\ + \quad 3 \quad 5 \quad 5 \\ \hline \quad 7 \quad 1 \quad 0 \end{array}$$

$$\begin{array}{r} 15. \quad \text{H} \quad \text{T} \quad \text{O} \\ \quad 6 \quad 1 \quad 9 \\ + \quad 1 \quad 9 \quad 5 \\ \hline \quad 8 \quad 1 \quad 4 \end{array}$$

$$\begin{array}{r} 16. \quad \text{H} \quad \text{T} \quad \text{O} \\ \quad 4 \quad 2 \quad 8 \\ + \quad 2 \quad 8 \quad 6 \\ \hline \quad 7 \quad 1 \quad 4 \end{array}$$

$$\begin{array}{r} 17. \quad \text{H} \quad \text{T} \quad \text{O} \\ \quad 3 \quad 9 \quad 8 \\ + \quad 2 \quad 9 \quad 6 \\ \hline \quad 6 \quad 9 \quad 4 \end{array}$$

$$\begin{array}{r} 18. \quad \text{H} \quad \text{T} \quad \text{O} \\ \quad 2 \quad 2 \quad 5 \\ + \quad 6 \quad 8 \quad 4 \\ \hline \quad 9 \quad 0 \quad 9 \end{array}$$

$$\begin{array}{r} 19. \quad \text{H} \quad \text{T} \quad \text{O} \\ \quad 6 \quad 9 \quad 6 \\ + \quad 1 \quad 0 \quad 6 \\ \hline \quad 8 \quad 0 \quad 2 \end{array}$$

$$\begin{array}{r} 20. \quad \text{H} \quad \text{T} \quad \text{O} \\ \quad 3 \quad 4 \quad 7 \\ + \quad 5 \quad 8 \quad 5 \\ \hline \quad 9 \quad 3 \quad 2 \end{array}$$

$$\begin{array}{r} 21. \quad \text{H} \quad \text{T} \quad \text{O} \\ \quad 1 \quad 8 \quad 8 \\ + \quad 2 \quad 9 \quad 9 \\ \hline \quad 4 \quad 8 \quad 7 \end{array}$$

$$\begin{array}{r} 22. \quad \text{H} \quad \text{T} \quad \text{O} \\ \quad 5 \quad 8 \quad 4 \\ + \quad 3 \quad 8 \quad 7 \\ \hline \quad 9 \quad 7 \quad 1 \end{array}$$

$$\begin{array}{r} 23. \quad \text{H} \quad \text{T} \quad \text{O} \\ \quad 4 \quad 8 \quad 0 \\ + \quad 3 \quad 8 \quad 6 \\ \hline \quad 8 \quad 6 \quad 6 \end{array}$$

$$\begin{array}{r} 24. \quad \text{H} \quad \text{T} \quad \text{O} \\ \quad 7 \quad 4 \quad 5 \\ + \quad 1 \quad 7 \quad 9 \\ \hline \quad 9 \quad 2 \quad 4 \end{array}$$

$$\begin{array}{r} 25. \quad \text{H} \quad \text{T} \quad \text{O} \\ \quad 1 \quad 8 \quad 7 \\ + \quad 1 \quad 5 \quad 8 \\ \hline \quad 3 \quad 4 \quad 5 \end{array}$$

$$\begin{array}{r} 26. \quad \text{H} \quad \text{T} \quad \text{O} \\ \quad 2 \quad 7 \quad 7 \\ + \quad 1 \quad 8 \quad 5 \\ \hline \quad 4 \quad 6 \quad 2 \end{array}$$

$$\begin{array}{r} 27. \quad \text{H} \quad \text{T} \quad \text{O} \\ \quad 1 \quad 8 \quad 9 \\ + \quad 1 \quad 6 \quad 6 \\ \hline \quad 3 \quad 5 \quad 5 \end{array}$$

$$\begin{array}{r} 28. \quad \text{H} \quad \text{T} \quad \text{O} \\ \quad 2 \quad 4 \quad 8 \\ + \quad 2 \quad 3 \quad 8 \\ \hline \quad 4 \quad 8 \quad 6 \end{array}$$

$$\begin{array}{r} 29. \quad \text{H} \quad \text{T} \quad \text{O} \\ \quad 2 \quad 7 \quad 7 \\ + \quad 2 \quad 8 \quad 4 \\ \hline \quad 5 \quad 6 \quad 1 \end{array}$$

$$\begin{array}{r} 30. \quad \text{H} \quad \text{T} \quad \text{O} \\ \quad 2 \quad 3 \quad 7 \\ + \quad 3 \quad 2 \quad 9 \\ \hline \quad 5 \quad 6 \quad 6 \end{array}$$

$$\begin{array}{r} 31. \quad \text{H} \quad \text{T} \quad \text{O} \\ \quad 3 \quad 2 \quad 4 \\ + \quad 2 \quad 8 \quad 8 \\ \hline \quad 6 \quad 1 \quad 2 \end{array}$$

$$\begin{array}{r} 32. \quad \text{H} \quad \text{T} \quad \text{O} \\ \quad 3 \quad 2 \quad 9 \\ + \quad 1 \quad 8 \quad 7 \\ \hline \quad 5 \quad 1 \quad 6 \end{array}$$

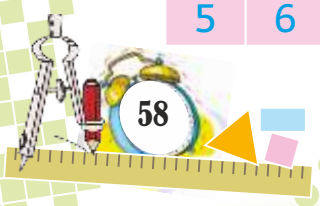



Quick Response 7.4

Solve the following word problems.

1. There are 146 apple trees and 247 pear trees in an orchard. How many trees are there in all in the orchard?

	H	T	O
	1	4	6
+	2	4	7
	3	9	3

2. On the last Saturday, 246 people visited the zoo. And on Sunday, 348 people visited the zoo. How many people visited the zoo on these two days?

	H	T	O
	2	4	6
+	3	4	8
	5	9	4

3. There are 486 men and 388 women workers in a company. How many total workers are there in the company?

	H	T	O
	4	8	6
+	3	8	8
	8	7	4

4. Abhinav bought 275 pieces of gulab jamuns and 285 pieces of burfis for a party. How many pieces of sweets did he buy for the party?

	H	T	O
	2	7	5
+	2	8	5
	5	6	0

5. There are 348 boy students and 362 girl students in a school. How many students are there in all in the school?

	H	T	O
	3	4	8
+	3	6	2
	7	1	0



6. There are 178 rose plants and 96 jasmine plants in a big garden. How many flowering plants are there in the garden altogether?

H	T	O
1	7	8
+	9	6
2	7	4

7. There are 236 male passengers and 208 female passengers in a train. Find the total number of passengers.

H	T	O
2	3	6
+	2	0
4	4	4

8. There are 461 red kites and 379 blue kites in a shop. How many kites are there in all in the shop?

H	T	O
4	6	1
+	3	7
8	4	0

9. There were 645 people in a stadium. 278 more people entered the stadium. How many people were there altogether in the stadium?

H	T	O
6	4	5
+	2	7
9	2	3



Subtract the following.

1.

H	T	O
3	7	4
-	3	1
3	4	3

2.

H	T	O
5	8	7
-	5	3
5	3	4

3.

H	T	O
6	9	7
-	6	6
6	3	1

4.

H	T	O
2	5	6
-	4	5
2	1	1

5.

H	T	O
1	6	8
-	4	2
1	2	6

6.

H	T	O
7	8	9
-	7	6
7	1	3

7.

H	T	O
9	5	7
-	5	7
9	0	0

8.

H	T	O
8	3	0
-	2	0
8	1	0





Quick Response 7.6

Subtract the following.

$$\begin{array}{r} \text{H} \quad \text{T} \quad \text{O} \\ 3 \quad 7 \quad 5 \\ - 1 \quad 2 \quad 4 \\ \hline 2 \quad 5 \quad 1 \end{array}$$

$$\begin{array}{r} \text{H} \quad \text{T} \quad \text{O} \\ 8 \quad 0 \quad 8 \\ - 4 \quad 0 \quad 5 \\ \hline 4 \quad 0 \quad 3 \end{array}$$

$$\begin{array}{r} \text{H} \quad \text{T} \quad \text{O} \\ 7 \quad 4 \quad 0 \\ - 3 \quad 2 \quad 0 \\ \hline 4 \quad 2 \quad 0 \end{array}$$

$$\begin{array}{r} \text{H} \quad \text{T} \quad \text{O} \\ 4 \quad 5 \quad 8 \\ - 3 \quad 0 \quad 8 \\ \hline 1 \quad 5 \quad 0 \end{array}$$

$$\begin{array}{r} \text{H} \quad \text{T} \quad \text{O} \\ 6 \quad 4 \quad 3 \\ - 3 \quad 4 \quad 3 \\ \hline 3 \quad 0 \quad 0 \end{array}$$

$$\begin{array}{r} \text{H} \quad \text{T} \quad \text{O} \\ 9 \quad 4 \quad 6 \\ - 4 \quad 3 \quad 5 \\ \hline 5 \quad 1 \quad 1 \end{array}$$

$$\begin{array}{r} \text{H} \quad \text{T} \quad \text{O} \\ 5 \quad 9 \quad 8 \\ - 1 \quad 9 \quad 6 \\ \hline 4 \quad 0 \quad 2 \end{array}$$

$$\begin{array}{r} \text{H} \quad \text{T} \quad \text{O} \\ 6 \quad 3 \quad 7 \\ - 1 \quad 3 \quad 5 \\ \hline 5 \quad 0 \quad 2 \end{array}$$



Quick Response 7.7

Subtract the following. Regroup if required.

$$\begin{array}{r} \text{H} \quad \text{T} \quad \text{O} \\ 1 \quad 2 \quad 4 \\ - \quad \quad 1 \quad 7 \\ \hline 1 \quad 0 \quad 7 \end{array}$$

$$\begin{array}{r} \text{H} \quad \text{T} \quad \text{O} \\ 2 \quad 9 \quad 6 \\ - \quad \quad 8 \quad 8 \\ \hline 2 \quad 0 \quad 8 \end{array}$$

$$\begin{array}{r} \text{H} \quad \text{T} \quad \text{O} \\ 4 \quad 7 \quad 0 \\ - \quad \quad 5 \quad 4 \\ \hline 4 \quad 1 \quad 6 \end{array}$$

$$\begin{array}{r} \text{H} \quad \text{T} \quad \text{O} \\ 7 \quad 6 \quad 7 \\ - \quad \quad 2 \quad 9 \\ \hline 7 \quad 3 \quad 8 \end{array}$$

$$\begin{array}{r} \text{H} \quad \text{T} \quad \text{O} \\ 5 \quad 2 \quad 7 \\ - 2 \quad 8 \quad 6 \\ \hline 2 \quad 4 \quad 1 \end{array}$$

$$\begin{array}{r} \text{H} \quad \text{T} \quad \text{O} \\ 3 \quad 2 \quad 0 \\ - 1 \quad 7 \quad 4 \\ \hline 1 \quad 4 \quad 6 \end{array}$$

$$\begin{array}{r} \text{H} \quad \text{T} \quad \text{O} \\ 6 \quad 0 \quad 5 \\ - 2 \quad 9 \quad 8 \\ \hline 3 \quad 0 \quad 7 \end{array}$$

$$\begin{array}{r} \text{H} \quad \text{T} \quad \text{O} \\ 4 \quad 2 \quad 4 \\ - 2 \quad 4 \quad 7 \\ \hline 1 \quad 7 \quad 7 \end{array}$$

$$\begin{array}{r} \text{H} \quad \text{T} \quad \text{O} \\ 5 \quad 6 \quad 4 \\ - 3 \quad 3 \quad 8 \\ \hline 2 \quad 2 \quad 6 \end{array}$$

$$\begin{array}{r} \text{H} \quad \text{T} \quad \text{O} \\ 6 \quad 0 \quad 5 \\ - 2 \quad 5 \quad 0 \\ \hline 3 \quad 5 \quad 5 \end{array}$$

$$\begin{array}{r} \text{H} \quad \text{T} \quad \text{O} \\ 7 \quad 6 \quad 8 \\ - 4 \quad 7 \quad 5 \\ \hline 2 \quad 9 \quad 3 \end{array}$$

$$\begin{array}{r} \text{H} \quad \text{T} \quad \text{O} \\ 8 \quad 6 \quad 2 \\ - 4 \quad 8 \quad 7 \\ \hline 3 \quad 7 \quad 5 \end{array}$$

$$\begin{array}{r} \text{H} \quad \text{T} \quad \text{O} \\ 5 \quad 4 \quad 0 \\ - 2 \quad 8 \quad 7 \\ \hline 2 \quad 5 \quad 3 \end{array}$$

$$\begin{array}{r} \text{H} \quad \text{T} \quad \text{O} \\ 3 \quad 7 \quad 6 \\ - 1 \quad 8 \quad 7 \\ \hline 1 \quad 8 \quad 9 \end{array}$$

$$\begin{array}{r} \text{H} \quad \text{T} \quad \text{O} \\ 9 \quad 4 \quad 3 \\ - 6 \quad 7 \quad 5 \\ \hline 2 \quad 6 \quad 8 \end{array}$$

$$\begin{array}{r} \text{H} \quad \text{T} \quad \text{O} \\ 8 \quad 0 \quad 0 \\ - 2 \quad 5 \quad 5 \\ \hline 5 \quad 4 \quad 5 \end{array}$$



$$\begin{array}{r} 17. \quad \begin{array}{|c|c|c|} \hline \text{H} & \text{T} & \text{O} \\ \hline 6 & 0 & 7 \\ \hline - & 3 & 2 & 9 \\ \hline 2 & 7 & 8 \\ \hline \end{array} \end{array}$$

$$18. \quad \begin{array}{|c|c|c|} \hline \text{H} & \text{T} & \text{O} \\ \hline 5 & 1 & 0 \\ \hline - & 1 & 4 & 8 \\ \hline 3 & 6 & 2 \\ \hline \end{array}$$

$$19. \quad \begin{array}{|c|c|c|} \hline \text{H} & \text{T} & \text{O} \\ \hline 7 & 4 & 5 \\ \hline - & 4 & 8 & 6 \\ \hline 2 & 5 & 9 \\ \hline \end{array}$$

$$20. \quad \begin{array}{|c|c|c|} \hline \text{H} & \text{T} & \text{O} \\ \hline 8 & 3 & 0 \\ \hline - & 5 & 7 & 6 \\ \hline 2 & 5 & 4 \\ \hline \end{array}$$



Quick Response 7.8

Subtract the following and check the answer.

1. $629 - 482$

$$\begin{array}{|c|c|c|} \hline \text{H} & \text{T} & \text{O} \\ \hline 6 & 2 & 9 \\ \hline - & 4 & 8 & 2 \\ \hline 1 & 4 & 7 \\ \hline \end{array} \quad + \quad \begin{array}{|c|c|c|} \hline \text{H} & \text{T} & \text{O} \\ \hline 1 & 4 & 7 \\ \hline + & 4 & 8 & 2 \\ \hline 6 & 2 & 9 \\ \hline \end{array}$$

2. $720 - 386$

$$\begin{array}{|c|c|c|} \hline \text{H} & \text{T} & \text{O} \\ \hline 7 & 2 & 0 \\ \hline - & 3 & 8 & 6 \\ \hline 3 & 3 & 4 \\ \hline \end{array} \quad + \quad \begin{array}{|c|c|c|} \hline \text{H} & \text{T} & \text{O} \\ \hline 3 & 3 & 4 \\ \hline + & 3 & 8 & 6 \\ \hline 7 & 2 & 0 \\ \hline \end{array}$$

3. $576 - 398$

$$\begin{array}{|c|c|c|} \hline \text{H} & \text{T} & \text{O} \\ \hline 5 & 7 & 6 \\ \hline - & 3 & 9 & 8 \\ \hline 1 & 7 & 8 \\ \hline \end{array} \quad + \quad \begin{array}{|c|c|c|} \hline \text{H} & \text{T} & \text{O} \\ \hline 1 & 7 & 8 \\ \hline + & 3 & 9 & 8 \\ \hline 5 & 7 & 6 \\ \hline \end{array}$$

4. $914 - 537$

$$\begin{array}{|c|c|c|} \hline \text{H} & \text{T} & \text{O} \\ \hline 9 & 1 & 4 \\ \hline - & 5 & 3 & 7 \\ \hline 3 & 7 & 7 \\ \hline \end{array} \quad + \quad \begin{array}{|c|c|c|} \hline \text{H} & \text{T} & \text{O} \\ \hline 3 & 7 & 7 \\ \hline + & 5 & 3 & 7 \\ \hline 9 & 1 & 4 \\ \hline \end{array}$$



Quick Response 7.9

Solve the following.

1. There were 784 passengers in a train. 348 passengers got down at the next station. How many passengers were left in the train?

$$\begin{array}{|c|c|c|} \hline \text{H} & \text{T} & \text{O} \\ \hline 7 & 8 & 4 \\ \hline - & 3 & 4 & 8 \\ \hline 4 & 3 & 6 \\ \hline \end{array}$$

2. There were 124 books in a shelf. Ria took out 86 of them. How many books were left in the shelf?

$$\begin{array}{|c|c|c|} \hline \text{H} & \text{T} & \text{O} \\ \hline 1 & 2 & 4 \\ \hline - & 8 & 6 \\ \hline & 3 & 8 \\ \hline \end{array}$$



3. There were 108 beads on a string. If 48 of them broke, how many beads were left on the string?

H	T	O
1	0	8
-	4	8
	6	0

4. Out of 472 toffees, Kavya and her friends ate 295. How many toffees were still left?

H	T	O	
4	7	2	
-	2	9	5
	1	7	7

5. Rohit got 575 marks in Term-1. He got 386 marks in Term-2. How many less marks did he get in Term-2 than Term-1?

H	T	O	
5	7	5	
-	3	8	6
	1	8	9

6. Junaid collected 250 stamps and his brother, Firoz collected 185 stamps. How many more stamps did Junaid collect than Firoz?

H	T	O	
2	5	0	
-	1	8	5
		6	5

7. A shopkeeper had 534 packets of chips. Out of these packets, she sold 420. How many packets were left?

H	T	O	
5	3	4	
-	4	2	0
	1	1	4

8. An egg-seller bought 612 eggs. But 174 of them broke. How many eggs were left with the egg-seller?

H	T	O	
6	1	2	
-	1	7	4
	4	3	8





Chapter Review

1. Add the following. Regroup if required.

a)

H	T	O
3	2	5
+	4	2
3	6	7

b)

H	T	O
4	6	3
+	2	8
4	9	1

c)

H	T	O
1	4	7
+	2	5
3	9	8

d)

H	T	O
2	8	4
+	3	4
6	3	2

e)

H	T	O
5	8	6
+	2	9
8	8	0

f)

H	T	O
4	9	8
+	4	6
9	6	4

2. Subtract the following. Regroup if required.

a)

H	T	O
4	8	7
-	5	4
4	3	3

b)

H	T	O
5	3	4
-	3	0
2	3	2

c)

H	T	O
8	6	0
-	2	2
6	3	6

d)

H	T	O
9	6	8
-	4	8
4	8	0

e)

H	T	O
8	0	0
-	5	4
2	5	5

f)

H	T	O
7	2	4
-	3	4
3	7	6

3. Solve the following.

a) There are 247 mango trees and 396 gauva trees in an orchard. Find the total numbers of trees.

2	4	7
+	3	9
6	4	3

b) Out of 625 students in a school, 447 are boys. Find the number of girl students.

6	2	5
-	4	4
1	7	8



Critical Thinking

Follow the arrows and write the missing numbers to make the sum correct.

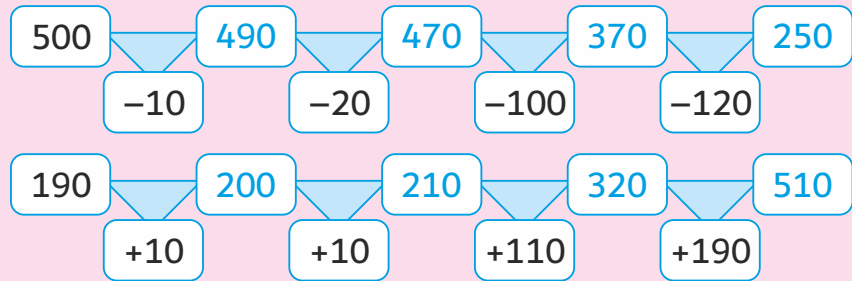

Life Skill

Anay saved ₹ 325 from his pocket money last year. This year he has saved ₹ 432. How much money has he saved in these two years? $325 + 432 = ₹ 757$

What is the benefit of saving money? *Write it yourself*

Social-emotional Learning

Mrs Ahana donates 150 notebooks, Mr Kaushik donates 264 and Mrs Rawat donates 325 notebooks to an orphanage. How many notebooks did they donate altogether? $150 + 264 + 325 = 739$ notebooks

Cross Curricular

There are 154 one-storey houses, 204 duplexes and 27 huts in a town. How many houses are there in the town altogether?



$$154 + 204 + 27 = 385 \text{ house}$$



8

Fractions

Colour half part of the slice of bread.

Do it yourself



Chapter Review

1. Tick (✓) the figures which are divided into equal parts.

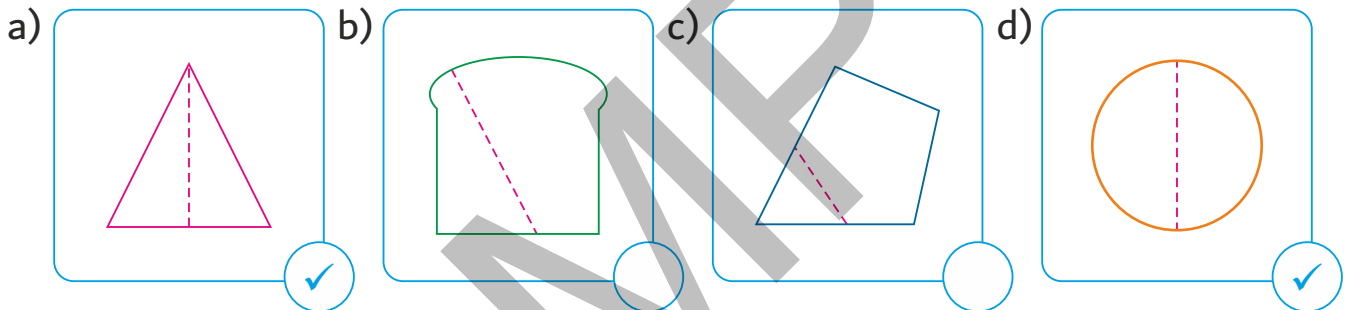

2. Colour each figure as mentioned.

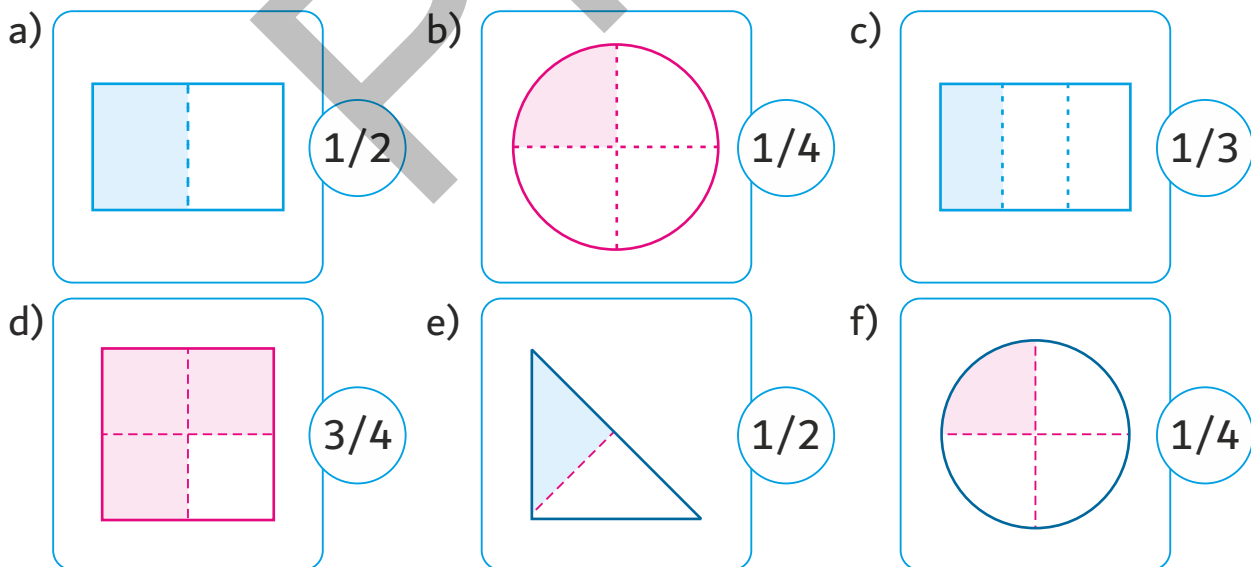

3. Write the coloured part of each figure in fraction.

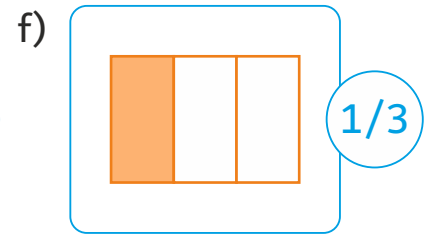
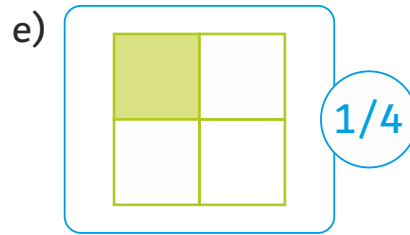
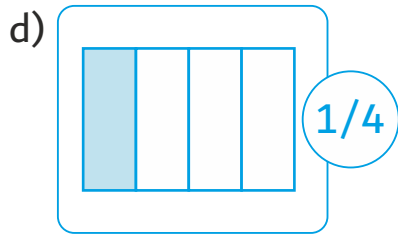
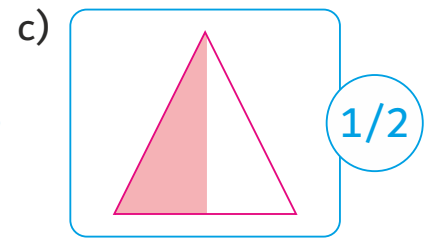
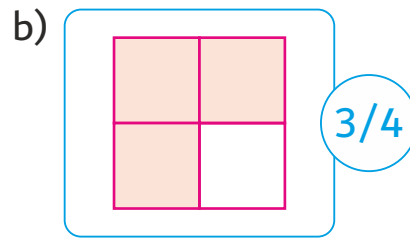
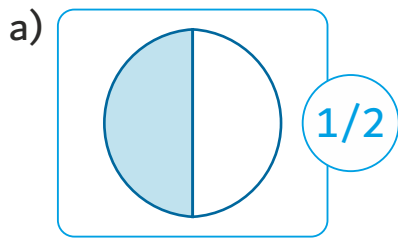

Critical Thinking

Which of these two figures represents bigger fraction? Do they represent equal fraction? Share with your classmates.

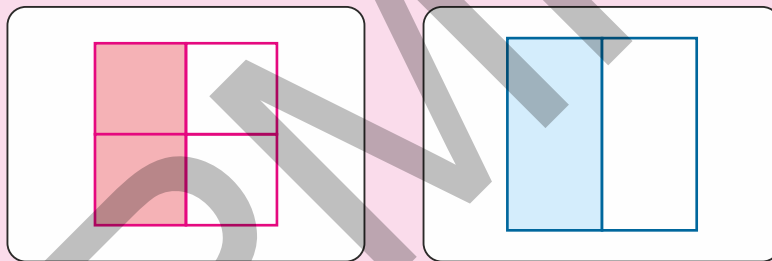

Ans. These figures represent equal fraction. Social-emotional Learning

Aarav's father has bought him a pizza. Meanwhile, two of his friends come to meet him. Should Aarav share pizza with them? What part of pizza should Aarav share with them so that each of them gets equal part?

Do it yourself



9

Measurement



Get Ready

1. How long is the pencil?

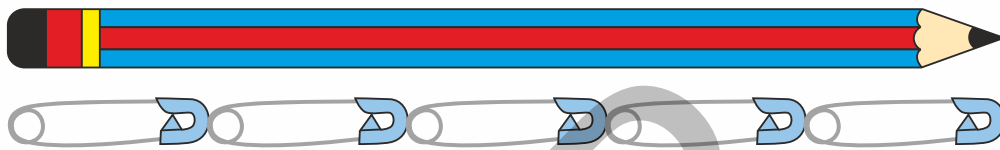

The pencil is safety pins long.

2. Tick (✓) the heavier object.

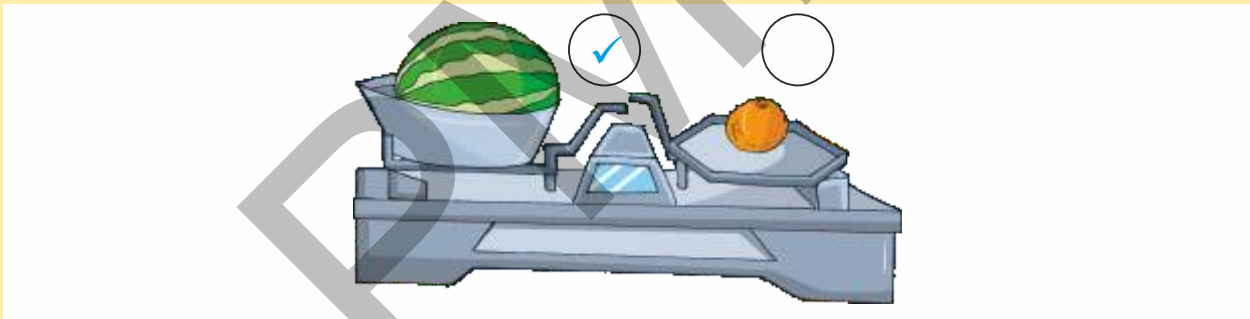

3. If 1 jug holds 4 cups of water, circle the number of cups that will fill the two jugs with water.

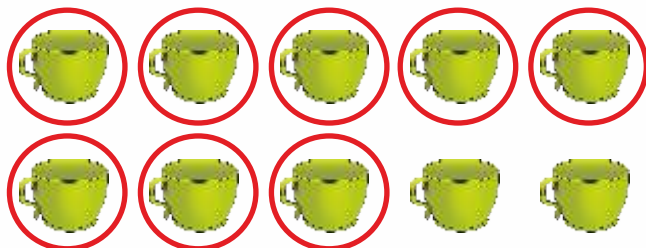



Quick Response 9.1

1. Measure the length of the following things using a ruler and write them.

Do it yourself

2. Write whether the lengths of the following are measured in m or cm.

a) The length of the blackboard _____ m _____

b) The length of a book _____ cm _____

c) The length of a car _____ m _____

d) The length of a mobile phone _____ cm _____



3. Write in metres.

a) 200 cm = _____ 2 m _____

b) 400 cm = _____ 4 m _____

c) 500 cm = _____ 5 m _____

d) 700 cm = _____ 7 m _____

e) 300 cm = _____ 3 m _____

f) 900 cm = _____ 9 m _____

4. Write in centimetres.

a) 1 m = _____ 100 cm _____

b) 3 m = _____ 300 cm _____

c) 5 m = _____ 500 cm _____

d) 6 m = _____ 600 cm _____

e) 8 m = _____ 800 cm _____

f) 9 m = _____ 900 cm _____





Quick Response 9.2

1. Write the weight of the following.

a)

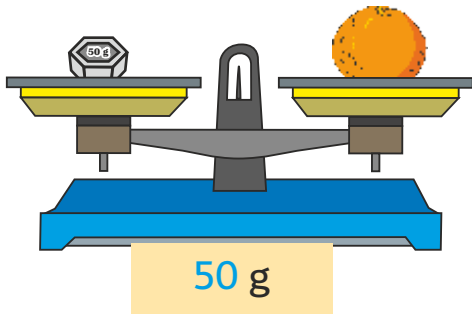

b)

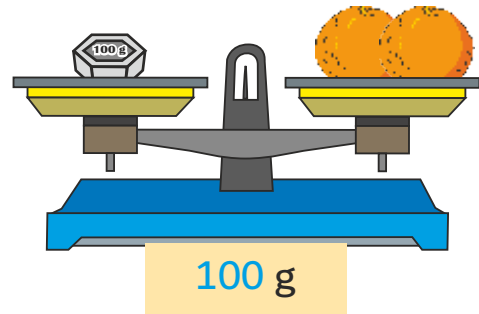

c)

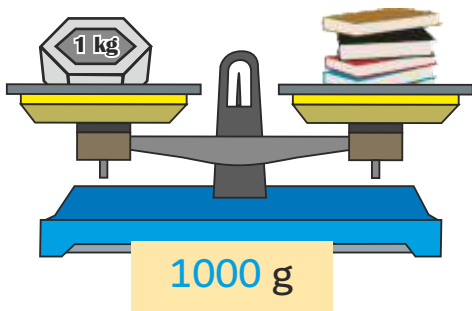

d)

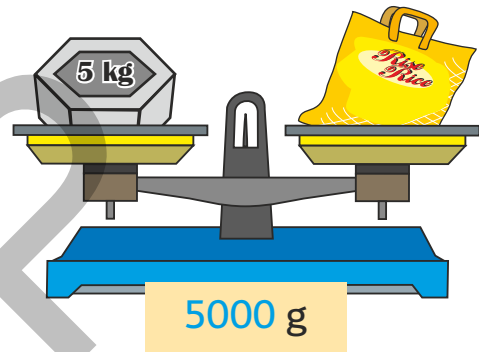

2. Write whether the weight of the following things are measured in g or kg.

a) A pen _____ g

b) A log of wood _____ kg

c) A toothbrush _____ g

d) A baby _____ kg

3. A shopkeeper has the weights given below. How will he use them to weight the following? One has been done for you.

b) 8 kg 5 kg + 2 kg + 1 kg

d) 3 kg 2 kg + 1 kg

c) 12 kg 10 kg + 2 kg

f) 17 kg 10 kg + 5 kg + 2 kg

e) 15 kg 10 kg + 5 kg





Quick Response 9.3

1. If a glass can hold 200 ml of water, find the capacity of the containers given below.



A thermos can hold **400** ml of water.



A jug can hold **600** ml of water.

2. Write whether the capacities of the following are measured in ml or l.

a) Water in a tanker _____ l



b) Soup in a bowl _____ ml



c) Medicine in a syringe _____ ml

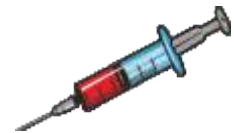

d) Vegetable oil in a tin _____ l





Quick Response 9.4

1. Add.

a)	m	cm
	12	51
+	23	24
	35	75

b)	m	cm
	20	21
+	15	37
	35	58

c)	m	cm
	32	40
+	34	20
	66	60

d)	m	cm
	51	43
+	17	12
	68	55

2. Subtract.

a)	m	cm
	38	57
-	24	33
	14	24

b)	m	cm
	58	78
-	32	53
	26	25

c)	m	cm
	94	98
-	54	43
	40	55

d)	m	cm
	88	96
-	45	36
	43	60



Quick Response 9.5

1. Add.

a)	kg	g
	12	250
+	14	125
	26	375

b)	kg	g
	24	104
+	34	272
	58	376

c)	kg	g
	71	855
+	15	100
	86	955

d)	kg	g
	42	625
+	37	230
	79	855

2. Subtract.

a)	kg	g
	58	690
-	37	530
	21	160

b)	kg	g
	87	855
-	52	725
	35	130

c)	kg	g
	65	895
-	25	745
	40	150

d)	kg	g
	96	980
-	72	740
	24	240





Quick Response 9.6

1. Add.

a)	l	ml
	14	234
+	31	342
	45	576

b)	l	ml
	36	150
+	32	425
	68	575

c)	l	ml
	54	750
+	24	120
	78	870

d)	l	ml
	72	472
+	16	105
	88	577

2. Subtract.

a)	l	ml
	57	847
-	23	524
	34	323

b)	l	ml
	69	910
-	43	710
	26	200

c)	l	ml
	86	780
-	54	450
	32	330

d)	l	ml
	98	850
-	28	850
	70	000



Chapter Review

1. Tick (✓) the correct option.

a) We use metre to measure _____.

i) weight

ii) length

iii) capacity

b) 1 metre is equal to _____.

i) 10 cm

ii) 100 cm

iii) 1000 cm

c) Which of the following is the greatest?

i) 5 kg

ii) 200 g

iii) 500 g

d) We use litre to measure _____.

i) length

ii) capacity

iii) weight



2. Solve the following.

a)	<table border="1"><tr><th>m</th><th>cm</th></tr><tr><td>15</td><td>25</td></tr><tr><td>+ 12</td><td>+ 32</td></tr><tr><td>27</td><td>57</td></tr></table>	m	cm	15	25	+ 12	+ 32	27	57	b)	<table border="1"><tr><th>m</th><th>cm</th></tr><tr><td>82</td><td>43</td></tr><tr><td>+ 14</td><td>+ 15</td></tr><tr><td>96</td><td>58</td></tr></table>	m	cm	82	43	+ 14	+ 15	96	58	c)	<table border="1"><tr><th>m</th><th>cm</th></tr><tr><td>64</td><td>85</td></tr><tr><td>- 20</td><td>- 34</td></tr><tr><td>44</td><td>51</td></tr></table>	m	cm	64	85	- 20	- 34	44	51	d)	<table border="1"><tr><th>m</th><th>cm</th></tr><tr><td>75</td><td>96</td></tr><tr><td>- 23</td><td>- 80</td></tr><tr><td>52</td><td>16</td></tr></table>	m	cm	75	96	- 23	- 80	52	16
m	cm																																						
15	25																																						
+ 12	+ 32																																						
27	57																																						
m	cm																																						
82	43																																						
+ 14	+ 15																																						
96	58																																						
m	cm																																						
64	85																																						
- 20	- 34																																						
44	51																																						
m	cm																																						
75	96																																						
- 23	- 80																																						
52	16																																						

3. Solve the following.

a)	<table border="1"><tr><th>kg</th><th>g</th></tr><tr><td>5</td><td>420</td></tr><tr><td>+ 2</td><td>+ 350</td></tr><tr><td>7</td><td>770</td></tr></table>	kg	g	5	420	+ 2	+ 350	7	770	b)	<table border="1"><tr><th>kg</th><th>g</th></tr><tr><td>15</td><td>650</td></tr><tr><td>+ 12</td><td>+ 230</td></tr><tr><td>27</td><td>880</td></tr></table>	kg	g	15	650	+ 12	+ 230	27	880	c)	<table border="1"><tr><th>kg</th><th>g</th></tr><tr><td>24</td><td>750</td></tr><tr><td>- 12</td><td>- 250</td></tr><tr><td>12</td><td>500</td></tr></table>	kg	g	24	750	- 12	- 250	12	500	d)	<table border="1"><tr><th>kg</th><th>g</th></tr><tr><td>85</td><td>960</td></tr><tr><td>- 43</td><td>- 640</td></tr><tr><td>42</td><td>320</td></tr></table>	kg	g	85	960	- 43	- 640	42	320
kg	g																																						
5	420																																						
+ 2	+ 350																																						
7	770																																						
kg	g																																						
15	650																																						
+ 12	+ 230																																						
27	880																																						
kg	g																																						
24	750																																						
- 12	- 250																																						
12	500																																						
kg	g																																						
85	960																																						
- 43	- 640																																						
42	320																																						

4. Solve the following.

a)	<table border="1"><tr><th>l</th><th>ml</th></tr><tr><td>4</td><td>460</td></tr><tr><td>+ 3</td><td>+ 320</td></tr><tr><td>7</td><td>780</td></tr></table>	l	ml	4	460	+ 3	+ 320	7	780	b)	<table border="1"><tr><th>l</th><th>ml</th></tr><tr><td>14</td><td>250</td></tr><tr><td>+ 35</td><td>+ 140</td></tr><tr><td>49</td><td>390</td></tr></table>	l	ml	14	250	+ 35	+ 140	49	390	c)	<table border="1"><tr><th>l</th><th>ml</th></tr><tr><td>28</td><td>980</td></tr><tr><td>- 15</td><td>- 780</td></tr><tr><td>13</td><td>200</td></tr></table>	l	ml	28	980	- 15	- 780	13	200	d)	<table border="1"><tr><th>l</th><th>ml</th></tr><tr><td>77</td><td>890</td></tr><tr><td>- 42</td><td>- 750</td></tr><tr><td>35</td><td>140</td></tr></table>	l	ml	77	890	- 42	- 750	35	140
l	ml																																						
4	460																																						
+ 3	+ 320																																						
7	780																																						
l	ml																																						
14	250																																						
+ 35	+ 140																																						
49	390																																						
l	ml																																						
28	980																																						
- 15	- 780																																						
13	200																																						
l	ml																																						
77	890																																						
- 42	- 750																																						
35	140																																						

Critical Thinking

A fruit seller has a weight of 200 g. In how many times will he be able to weight 1 kg of apple?



5

Life Skill

Apart from main food items, Aditi consumes 50 grams of fruits, 20 grams of butter and 100 grams of vegetables every day. Find the total quantity of fruits, butter and vegetables.

$$50 + 20 + 100 = 170 \text{ grams}$$



10

Money



Get Ready

1. Write the value of these notes and coins.



₹100



₹ 5



₹50



2. Match the following.



₹ 30

₹ 57

₹ 25

₹ 12

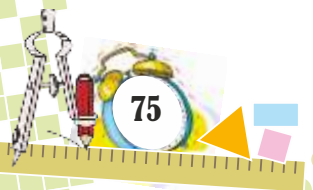



Quick Response 10.1

1. Write the following amounts in figure.

- a) 8 rupees 35 paise = ₹ 8.35
- b) 12 rupee 50 paise = ₹ 12.50
- c) 25 rupees 75 paise = ₹ 25.75
- d) 50 rupees 10 paise = ₹ 50.10
- e) 60 rupees 25 paise = ₹ 60.25



2. Write the following amounts in words.

- a) ₹ 9.55 = 9 rupees 55 paise
- b) ₹ 15.60 = 15 rupees 60 paise
- c) ₹ 25.75 = 25 rupees 75 paise
- d) ₹ 35.80 = 35 rupees 80 paise
- e) ₹ 52.40 = 52 rupees 40 paise



Quick Response 10.2

1. Add the following.

- | | | | | | | | | | |
|----|------------------------|----|------------------------|----|--------------------------|----|-----------------------|----|------------------------|
| a) | ₹ 20
+ ₹ 10
₹ 30 | b) | ₹ 50
+ ₹ 20
₹ 70 | c) | ₹ 100
+ ₹ 10
₹ 110 | d) | ₹ 60
+ ₹ 5
₹ 65 | e) | ₹ 70
+ ₹ 20
₹ 90 |
|----|------------------------|----|------------------------|----|--------------------------|----|-----------------------|----|------------------------|





2. Match the following sets of money with the price of objects.

a) 

b) 

c) 

d) 

i) 

ii) 

iii) 

iv) 

Quick Response 10.3

1. Add the money.

a)	₹	p	b)	₹	p	c)	₹	p	d)	₹	p
	12	35		44	30		37	40		54	65
+	23	20	+	45	45	+	51	50	+	32	30
	35	55		89	75		88	90		86	95

2. Subtract the money.

a)	₹	p	b)	₹	p	c)	₹	p	d)	₹	p
	44	75		58	60		96	85		87	90
-	12	35	-	34	50	-	50	30	-	60	90
	32	40		24	10		46	55		27	00



Quick Response 10.4

Solve the following.

1. Mother gave Ananya ₹50 and her father gave her ₹100. How much money does she have now altogether?



₹	p
50	00
+ 100	00
150	00

2. There were ₹75.50 in the money bank. Ria put ₹20 more in it. How much money is there in the money bank now?



₹	p
75	50
+ 20	00
95	50

3. Rohit buys an ice-cream for ₹30. He gives ₹50 to the ice-cream vendor. How much money will he get back?



₹	p
50	00
- 30	00
20	00

4. Soumya buys a toy for ₹120. She gives ₹150 to the shopkeeper. How much money will she get back?



₹	p
150	00
- 120	00
30	00

5. Ramya buys a notebook for ₹12. She gives a 20-rupee note to the shopkeeper. How much money will she get back?



₹	p
20	00
- 12	00
8	00

Chapter Review

1. Write the following amounts in figures.

a) 15 rupees 85 paise : ₹ 15.85

b) 95 rupees 60 paise : ₹ 95.60



2. Write the following amounts in words.

a) ₹ 17.15 : 17 rupees 15 paise

b) ₹ 25.45 : 25 rupees 45 paise

3. Find the total sum.



₹ 72



₹ 610

4. Add or subtract the following.

a)

₹	p
42	30
+	35 20
77	50

b)

₹	p
88	75
-	46 25
42	50

5. Solve the following.

a) Rohit had ₹ 125 with him. His father gave him ₹ 100. How much money does he have now?

₹	p
125	00
+	100 00
225	00

b) Ria had ₹ 95.50. She bought a pen for ₹ 15.50. How much money is left with her?

₹	p
95	50
-	15 50
80	00

Critical Thinking

Ranjana has two 5-rupee coins, three 10-rupee coins, five 2-rupee coins and fifteen 1-rupee coins. How much money does she have?



65



■■■ Communication Skill

Ria bought a pen for ₹20. She gave a 50-rupee note to the shopkeeper. By mistake, the shopkeeper returned her ₹40. But Ria returned ₹10 to the shopkeeper. The shopkeeper thanked her.

How much more money did the shopkeeper return? _____ ₹ 10

What quality do you see in Ria? _____ Honesty

What value does the act of Ria depict? Share with the class.

Answer it yourself

PMP





Get Ready

1. Label the minute hand and hour hand of the clock.

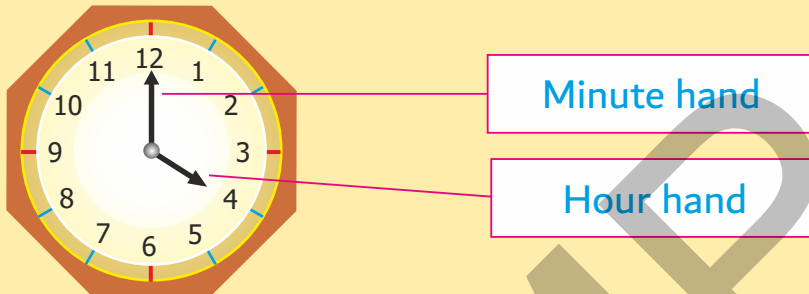

2. Write the time shown in the clocks.

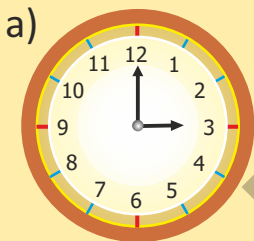

3 o'clock

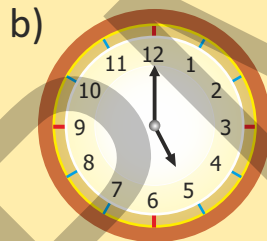

5 o'clock

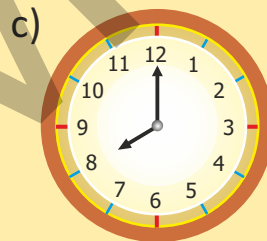

8 o'clock

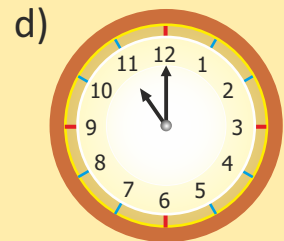

11 o'clock

3. Draw the hour hand in the clocks according to the given time.



7 o'clock

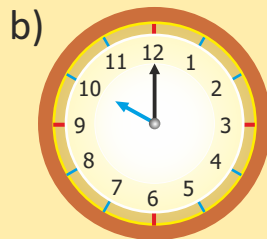

10 o'clock

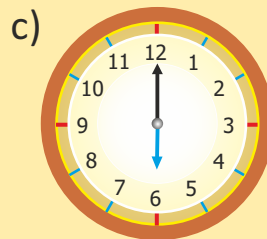

6 o'clock

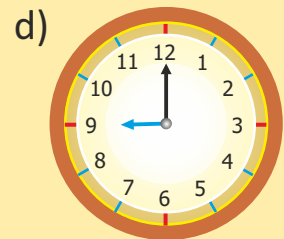

9 o'clock





Quick Response 11.1

1. Write the given time in both ways.

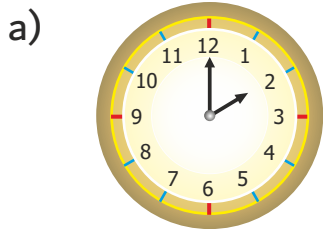

2 o'clock

2:00

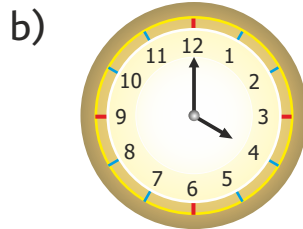

4 o'clock

4:00

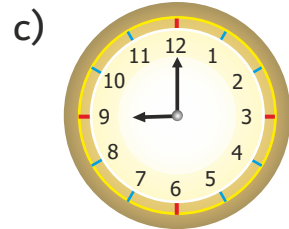

9 o'clock

9:00

2. Draw hands in the following clocks according to the given time.

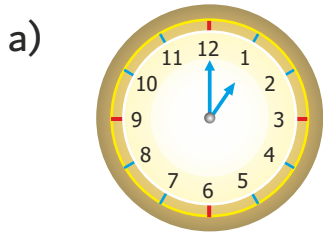

1:00

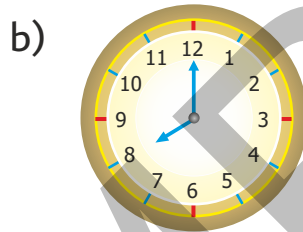

8:00

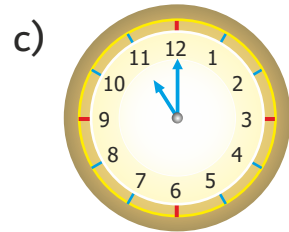

11:00



Quick Response 11.2

1. Write the time shown by the clocks.

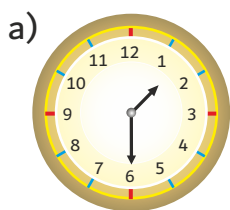

Half past 1

1:30

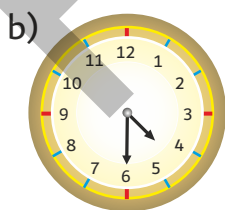

Half past 4

4:30

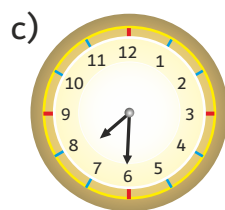

Half past 7

7:30

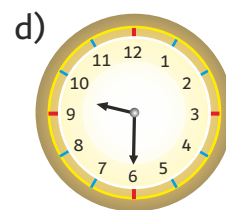

Half past 9

9:30

2. Draw hands of the clocks according to the given time.

a) 3:30



b) 5:30



c) 8:30



d) 10:30

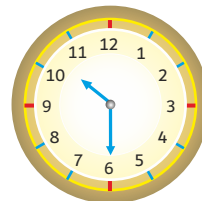



Quick Response 11.3

Write the time shown by the clocks.

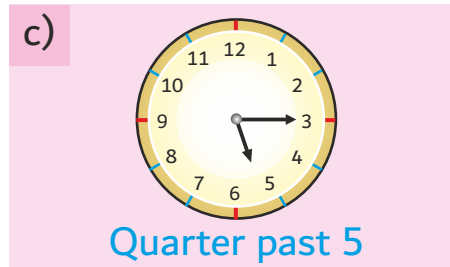
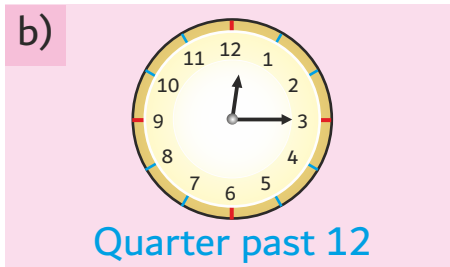
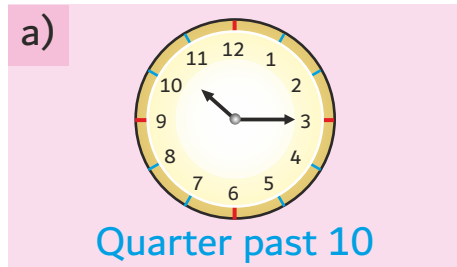

Quick Response 11.4

Write the time shown by the clocks.

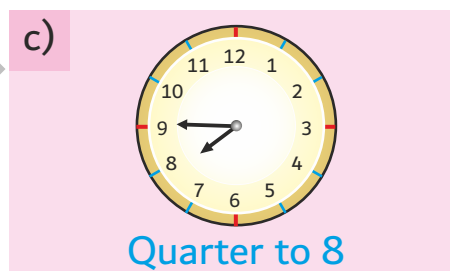
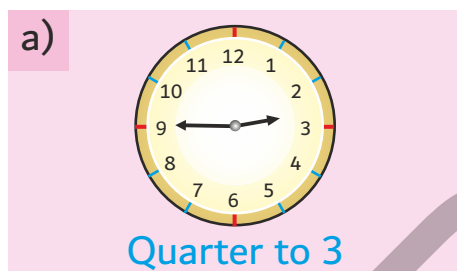

Quick Response 11.5

Fill in the blanks.

1. Monday is the first day of the week.
2. There are 7 days in a week.
3. Tuesday comes just after Monday.
4. Sunday is the last day of the week.
5. Saturday comes between Friday and Sunday.
6. The fifth day of the week is Friday.
7. Wednesday comes between Tuesday and Thursday.





Quick Response 11.6

Fill in the blanks.

1. If today is Thursday, yesterday was Wednesday.
2. If today is Saturday, tomorrow will be Sunday.
3. If yesterday was Wednesday, today is Thursday.
4. If tomorrow is Sunday, today is Saturday.
5. If yesterday was Tuesday, today is Wednesday.
6. If yesterday was Monday, tomorrow will be Wednesday.
7. If tomorrow is Wednesday, yesterday was Monday.



Quick Response 11.7

Fill in the blanks.

1. January is the first month of the year.
2. July comes just after June.
3. September comes between August and October.
4. There are 30 days in November.
5. February has 28 or 29 days.
6. December is the last month of the year.



Quick Response 11.8

Fill in the blanks.

1. How many Sundays are there in this month? four
2. On which date is the first Saturday? 3
3. Which day is on the last date of the month? Saturday
4. What is the date on the last Monday of the month? 26
5. How many days are there in the month? 31



Match the following.

- | | |
|---------------------|-----------------|
| 1. December-January | a) Hemant Ritu |
| 2. June-July | b) Grishma Ritu |
| 3. October-November | c) Shishir Ritu |
| 4. February-March | d) Varsha Ritu |
| 5. April-May | e) Vasant Ritu |

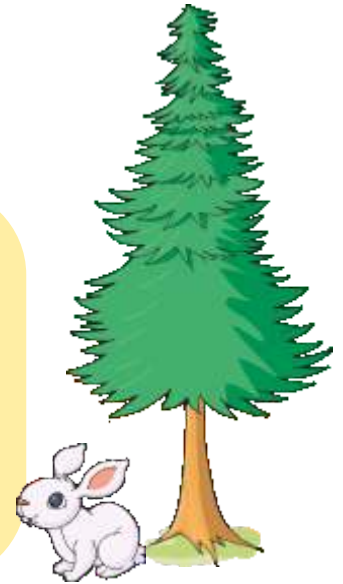



Chapter Review

1. Tick (✓) the correct option.

- a) The minute hand takes a complete round in _____.
 i) 60 minutes ii) 90 minutes iii) 30 minutes
- b) _____ comes just after Monday.
 i) Wednesday ii) Tuesday iii) Thursday
- c) _____ is the last day of the week.
 i) Monday ii) Sunday iii) Saturday
- d) July comes between June and _____.
 i) August ii) September iii) October

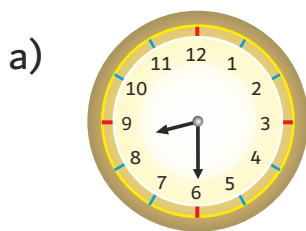
2. Look at the clock and write the time in two ways.



Half past 8

8:30

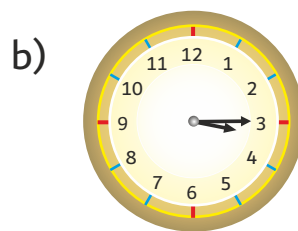

Quarter past 3

3:15

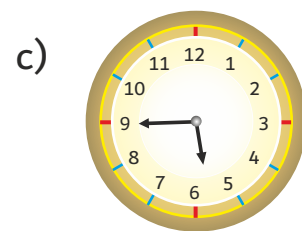

Quarter to 6

5:45



3. Fill in the blanks.

- a) There are 12 months in a year.
- b) In a leap year, the month of February has 29 days.
- c) There are 7 days in a week.
- d) In a leap year, there are 366 days in a year.
- e) Summer season is called Grishma Ritu in Hindi.

Critical Thinking

Look at the clock. It is running late by 15 minutes. Can you tell the actual time?

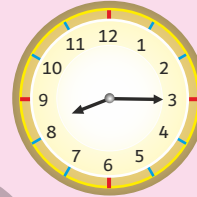

8:30

Language Skill

Time is precious. We should not waste it. Instead we should use time for some constructive work. Write about any constructive activity that you do on holidays in your notebook.

Write it yourself





Get Ready

1. Colour the shapes as per the instructions given below.

Do it yourself

2. Draw and colour the figures that will come next.

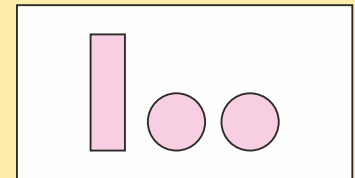
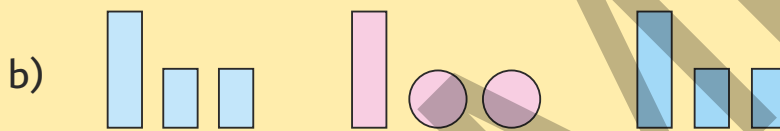
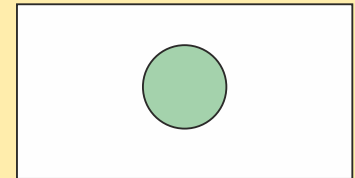
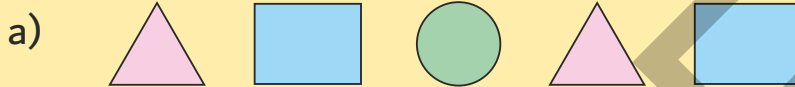

Quick Response 12.1

Write the number of sides and corners for the given figures.

1.

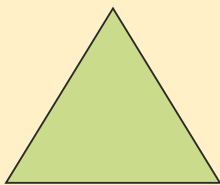

3 sides

3 corners

2.



4 sides

4 corners

3.



4 sides

4 corners

4.

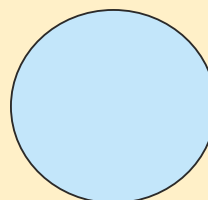

0 sides

0 corners





Quick Response 12.2

Count and write how many horizontal, vertical and slanting lines each of the following shapes has.

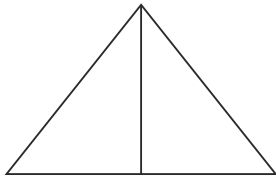

Horizontal line

1

Vertical line

1

Slanting line

2

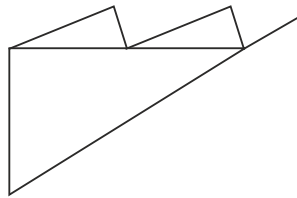

Horizontal line

1

Vertical line

1

Slanting line

5

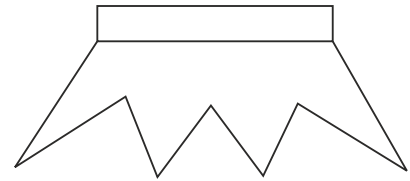

Horizontal line

2

Vertical line

2

Slanting line

8



Quick Response 12.3

1. Fill in the blanks.

- A cube has 6 faces, 12 edges and 8 corners.
- A cuboid has 6 faces, 12 edges and 8 corners.
- A sphere has 1 face but no edges and no corners.
- A cone has 2 faces, 1 edge and 1 corner.
- A cylinder has 3 faces, 2 edges and 0 corners.



3. Write the number that will come next.

- a) 5 10 15 20 25
- b) 100 95 90 85 80
- c) 2 4 8 16 32
- d) 12 22 32 42 52



1. Tick (✓) the correct option.

- a) How many sides are there in a triangle?
i) 3 ii) 4 iii) 5
- b) How many corners are there in a square?
i) 3 ii) 4 iii) 6
- c) How many sides are there in a rectangle?
i) 3 ii) 4 iii) 5
- d) Which of the following has no sides?
i) square ii) triangle iii) circle

2. Name these straight lines.

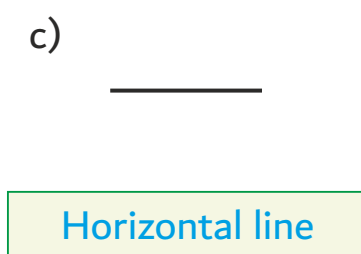
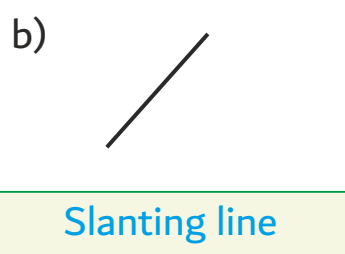
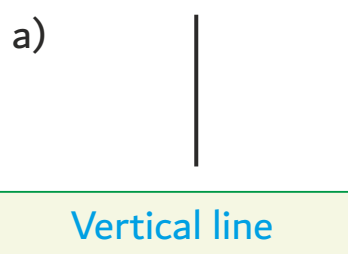

3. Name these solid shapes.

a)

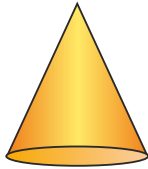

Cone

b)

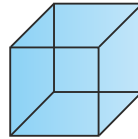

Cube

c)

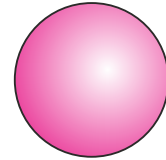

Sphere

4. Complete the pattern.

a)

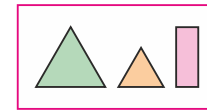
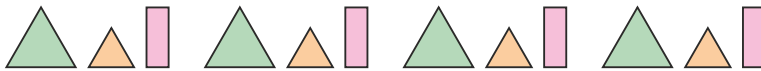

b)

AB

AC

AD

AE

AF

Critical Thinking

Tick (✓) the box in the answers column that will fit in the box with (?) mark.

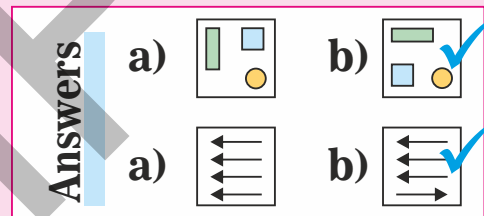
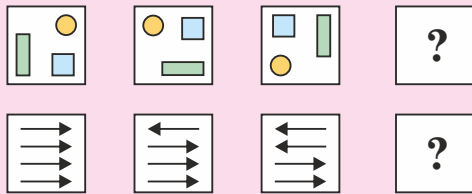

Activity

Many families in India make rangoli at their homes on festivals. Making a rangoli is an art. Make a design of rangoli on a chart paper and fill crayon colours in it. Display it in your classroom.

Do it yourself

Think and Discuss

Observe a square and a cube carefully. What is the difference between them? Share with the class.

Answer it yourself



How many each of the following are there in the parking lot?

1.



6

2.



7

3.



8

4.



5



Quick Response 13.1

1. Ria and her friends bought some ice-creams which are shown below.

Now answer the following questions.

- a) How many ice-creams did they buy altogether? 33
- b) Which kind of ice-cream was bought in the largest number? Kulfi
- c) How many more kulfis were bought than cones? 2

2. Ashu has the following toys. Read the table carefully.

Now answer the following questions.

- a) How many toy ducks does Ashu have? 12
- b) How many toys does Ashu have in all? 28
- c) How many more toy ducks does he have than dolls? 5



3. Here is given a table containing the weight of 4 students. Read the table carefully.

Now answer the following questions.

- a) Who is the heaviest amongst all the students? Anay
- b) Is Alia heavier than Shivam? No
- c) How much is Anay heavier than Riyan? $28 - 20 = 8 \text{ Kg}$

4. The following table shows the number of members in 5 families.

Now answer the following questions.

- a) How many members are there in Family B? 4
- b) Does Family C have more members than Family A? Yes
- c) How many more members are there in Family E than that of Family D? $8 - 3 = 5$



Chapter Review

Look at the following table carefully. It is showing the height of eight students of a class.

Now answer the following questions.

1. Who is the tallest?
Firoz Ali
2. Who is the shortest?
Chhaya Sen
3. Which two students are of equal height?
Ananya Jain and Aditi Singh
4. What is the difference between the height of Chhaya Sen and Simran Kaur?
 $108 - 90 = 18 \text{ cm}$



Critical Thinking

Look at the given data and the pictograph based on it. There is a mistake in the pictograph. Find the mistake.

Sport	Number of Students
Cricket	3
Football	6
Badminton	4
Hockey	2

Sport	Number of Students
Cricket	☺☺☺
Football	☺☺☺☺☺☺
Badminton	☺☺☺☺
Hockey	☺☺

Communication Skill

Given below is a table showing the number of road accidents that occurred in a city in different seasons.

Can you tell why most number of accidents occur in the rainy season?

Talk about it in the class.

Summer	Rainy	Winter
24	58	36

Answer it yourself



Model Test Paper - II

(Based on Chapters 7 to 12)

1. Tick (✓) the correct option.

a) $88 - 7 = ?$

- i) 71 ii) 81 iii) 80

b) Length is measured in _____.

- i) metre ii) gram iii) litre

c) Which of the following is the largest amount?

- i) ₹ 15.27 ii) ₹ 15.30 iii) ₹ 15.12

d) 1 hour = _____ minutes.

- i) 30 ii) 50 iii) 60

e) Which month comes just after July?

- i) September ii) June iii) August

2. Add or subtract the following.

a)	<table border="1"><tr><td>4</td><td>2</td><td>3</td></tr><tr><td>+</td><td>2</td><td>4</td><td>6</td></tr><tr><td colspan="3">669</td></tr></table>	4	2	3	+	2	4	6	669			b)	<table border="1"><tr><td>5</td><td>1</td><td>7</td></tr><tr><td>+</td><td>2</td><td>8</td><td>9</td></tr><tr><td colspan="3">806</td></tr></table>	5	1	7	+	2	8	9	806			c)	<table border="1"><tr><td>9</td><td>7</td><td>9</td></tr><tr><td>-</td><td>7</td><td>6</td><td>5</td></tr><tr><td colspan="3">214</td></tr></table>	9	7	9	-	7	6	5	214			d)	<table border="1"><tr><td>6</td><td>4</td><td>8</td></tr><tr><td>-</td><td>2</td><td>7</td><td>7</td></tr><tr><td colspan="3">371</td></tr></table>	6	4	8	-	2	7	7	371		
4	2	3																																													
+	2	4	6																																												
669																																															
5	1	7																																													
+	2	8	9																																												
806																																															
9	7	9																																													
-	7	6	5																																												
214																																															
6	4	8																																													
-	2	7	7																																												
371																																															

3. Add or subtract.

a)	<table border="1"><thead><tr><th>m</th><th>cm</th></tr></thead><tbody><tr><td>20</td><td>25</td></tr><tr><td>+</td><td>15</td><td>30</td></tr><tr><td>35</td><td>55</td></tr></tbody></table>	m	cm	20	25	+	15	30	35	55	b)	<table border="1"><thead><tr><th>kg</th><th>g</th></tr></thead><tbody><tr><td>25</td><td>360</td></tr><tr><td>+</td><td>31</td><td>130</td></tr><tr><td>56</td><td>490</td></tr></tbody></table>	kg	g	25	360	+	31	130	56	490	c)	<table border="1"><thead><tr><th>l</th><th>ml</th></tr></thead><tbody><tr><td>72</td><td>750</td></tr><tr><td>-</td><td>42</td><td>240</td></tr><tr><td>30</td><td>510</td></tr></tbody></table>	l	ml	72	750	-	42	240	30	510
m	cm																															
20	25																															
+	15	30																														
35	55																															
kg	g																															
25	360																															
+	31	130																														
56	490																															
l	ml																															
72	750																															
-	42	240																														
30	510																															



4. Add or subtract.

a)

₹	p
25	20
+	14
15	
39	35

b)

₹	p
72	24
+	15
75	
87	99

c)

₹	p
67	95
-	25
35	
42	60

5. Fill in the blanks.

- a) There are 7 days in a week.
- b) Friday comes just after Thursday.
- c) February has 29 days in a leap year.
- d) Summer season is called Grishma Ritu in Hindi.

6. Fill in the blanks.

- a) There are 6 faces of a cube.
- b) A cuboid has 12 edges.
- c) A cone has 1 corners.
- d) A cylinder has 3 faces.

7. Read the following table containing the marks obtained by four students in Maths. Answer the given questions.

Name	Surbhi	Rajat	Rohan	Kamya
Marks	79	84	82	96

- a) Who got the highest marks? Kamya
- b) What are the marks obtained by Rohan? 82
- c) How many students have got more than 80 marks? 3

